

Transmission Processes in Linear Systems

Hermann Härtel

(haertel@astrophysik.uni-kiel.de)

Guest Scientist at:

ITAP - Institute for Theoretical Physics und Astrophysics

University Kiel

Leibnizstr. 15

List of Contents

Part 1: Transmission Processes in Mechanical Systems	5
Basics about properties of gases	5
Transmission processes in a linear tube	7
Superposition	17
Transmission in closed circular systems	19
Part 2: Transmission in Electrical Systems	27
Introduction	27
Transmission processes on a double line	29
Reflection at a terminating resistor	37
Impedance - Wave resistance	41
Series and parallel circuits	45

Part 1: Transmission Processes in Mechanical Systems

Introduction

Part 1 of the following tutorial serves mainly as preparation for a course in electricity about transmission processes on a double line. The main topics are wave transmission, superposition and reflection.

Based on the assumption that mechanical systems are easier for newcomers to conceptualize than electrical ones, the listed topics are first applied to transmission processes within linear and circular tubes filled with gas.

In part 2 the same topics are repeated and applied to the electrical case of transmission processes on a double line, demonstrating the similarities and differences between these two systems.

The assumption and hope is that the invested extra time for studying the mechanical systems will pay off as added value in respect to deeper understanding, increased interest in topics of physics and technology and higher motivation for continuous learning.

1.1. Basics about properties of gases

To study the dynamic behavior of gas or liquid depends on some basic knowledge about the molecular structure of these media, about the difference between thermal and drift velocity, the definition of pressure a.o.

Such knowledge is presented in the following chapter, supported by a specially developed simulation program, developed by Jose-Miguel Zamarrow.

1.1.1. Microscopic view of a gas

Given is a long, gas-filled pipe, of which only a small section is shown (Fig. 1.1.1.).

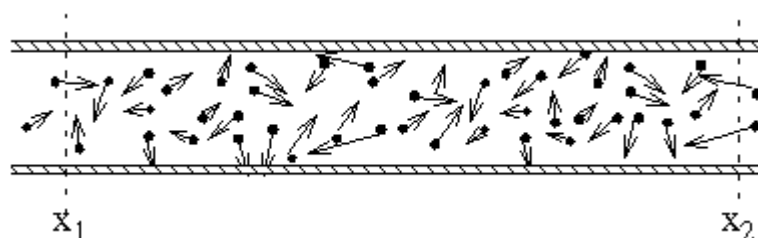

Fig.: 1.1.1. Thermal velocity of gas atoms or molecules

Such a gas consists of isolated atomic or molecular particles moving at relatively high speeds and constantly colliding with each other or the walls.

1.1.2. Data of air at room temperature

Air is a mixture of about 20% Oxygen molecules O_2 and 80% Nitrogen molecules N_2 .

At room temperature and normal atmospheric pressure the average velocity of the Oxygen and Nitrogen molecules is about 480 m/s. The average number of collisions

per second of a molecule with its neighbour is of the order of 10^8 / s. The mean free path between two collisions is about 6×10^{-8} m.

1.1.3. Pressure and density

In physics the term pressure describes a state where a force is acting on a certain area. If the size of the force F and the size of the area a is known, the amount of pressure can be determined as F/a .

Example:

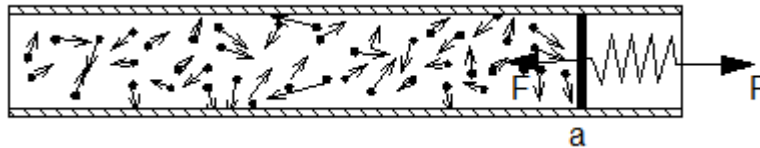

Fig.: 1.1.2. Pressure on a wall, caused by colliding particles

If the area a on the right, which is constantly hit by the particles, is movable and can be kept in balance by a force F , then the pressure on this area is equal to $P=F/a$.

The pressure of a gas is depending on the number of atoms or molecules which strike the chosen area per unit of time. This number is proportional to the density of a gas, i.e. the number of particles per unit of volume. Pressure is furthermore depending on the mean velocity of the microscopic particles.

1.1.4. Thermal velocity and homogenous distribution

The temperature of a gas is explained at the microscopic level by the random movement of the atoms or molecules.

The higher the mean velocity of the molecules, the higher the temperature of the gas. This thermal motion and the high number of collisions causes the particles to spread evenly through the available space.

This homogenous distribution can only be disturbed by external influences. Without any external disturbance this homogeneous distribution will always remain. After an external temporary disturbance the gas will automatically revert to the original even distribution.

1.1.5. Drifting velocity

The thermal velocity has to be distinguished from another type of motion, the flow of a gas, where all the particles in a gas receive the same drift velocity in one direction. Since all molecules are involved in the same sense, such a flow is observable on a macroscopic scale.

Thermal velocity and drift velocity are superimposed in a gas.

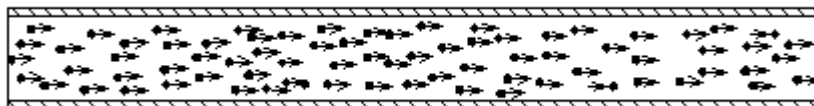

Fig.: 1.1.3. Drifting velocity (without indication of thermal velocity)

As a rule the magnitude of the drifting velocity is much smaller than the magnitude of the thermal velocity. A typical value ranges between several mm to m per second while the average thermal velocity of oxygen or nitrogen molecules in a gas at normal conditions is about 450 m/s.

Transmission line

1.2. Transmission processes in a rectilinear tube

In analogy to an electric transmission line it is assumed that the mechanical system, which will be studied in the following, consists of a long, thin and rectilinear tube. Differences within a cross section of the tube can be neglected.

The internal gas or liquid should flow only with rather small drifting speeds so that no effect of turbulence will occur. Under such conditions the effect of transmission, superposition and reflection can be based as a first approximation on the same equations and algorithm as for the electric transmission line.

1.2.1. Representation of pressure P in abstract form

A gas under normal conditions consists of an immensely large number of molecular particles, which cannot be represented graphically. Nevertheless, it is possible to depict regions of varying pressure within a tube using abstract means instead of moving and colliding particles.

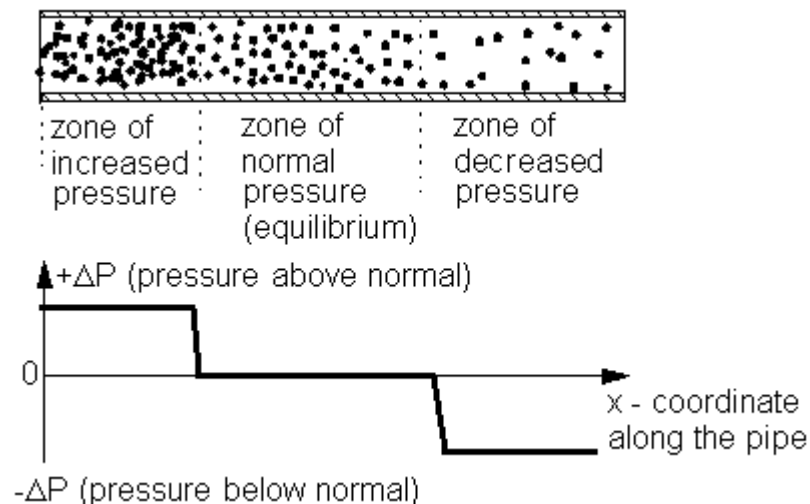

Fig.: 1.2.1. Graphical representation of pressure along a pipe

The horizontal axis of the graph represents the position in the direction of the pipe. The vertical axis represents the pressure.

A pressure of zero units within a gas is only possible if the tube is empty or if there is no thermal velocity of the gas atoms or molecules i.e. at 0^0 Kelvin. Under normal conditions a pressure always exists within a gas.

For practical reasons the pressure which exists at equilibrium is set to zero. Pressure above or below normal is then indicated as $+\Delta P$ and $-\Delta P$ respectively.

1.2.2. Representation of current I in abstract form

If a flow of gas through a tube has to be represented, it is practically impossible to do so by showing the motion of the individual particles. The drifting velocity of the particles in the direction of the tube is - as a rule - much smaller than the thermal velocity and therefore could not be visualized. Again we shall use a more abstract form to represent a flow of gas.

This is introduced in the following diagram.

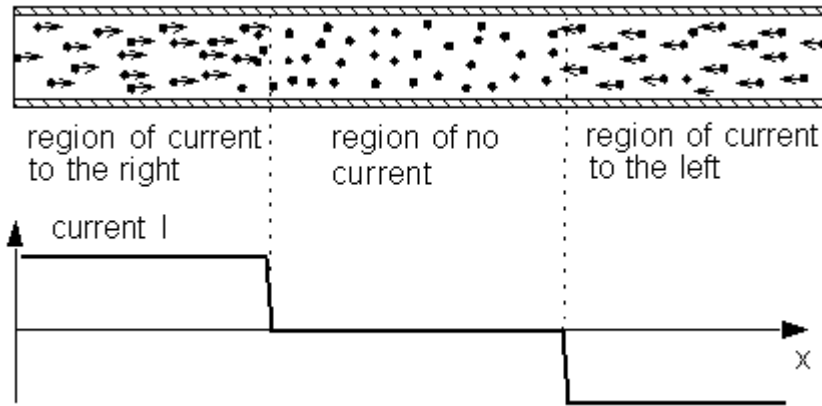

Fig.: 1.2.2. Graphical representation of current

The horizontal axis of the graph represents the position along the pipe, as before. The vertical axis represents the drift velocity or current (positive for a current to the right, negative for a current to the left).

1.2.3. Positive and negative direction of transmission

Positive and negative numbers can be arranged on a straight line where the sign of the numbers indicates the direction in which the number has to be placed in respect to the zero point.

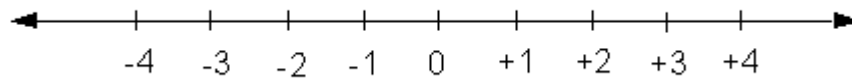

Fig.: 1.2.3. Positive and negative numbers as indication of orientation along a given direction

In the same way the direction of a current can be determined but only if the current is flowing in parallel to a per-defined direction. Any such direction has two opposite orientations which are usually named as positive and negative. The same holds for the orientation of a current, as long as it is flowing parallel to a given direction.

1.2.4. Transmission of a pulse

A pulse inside of tube represents a zone with higher pressure (higher density of particles), where the particles within this zone have a common drift velocity in one direction.

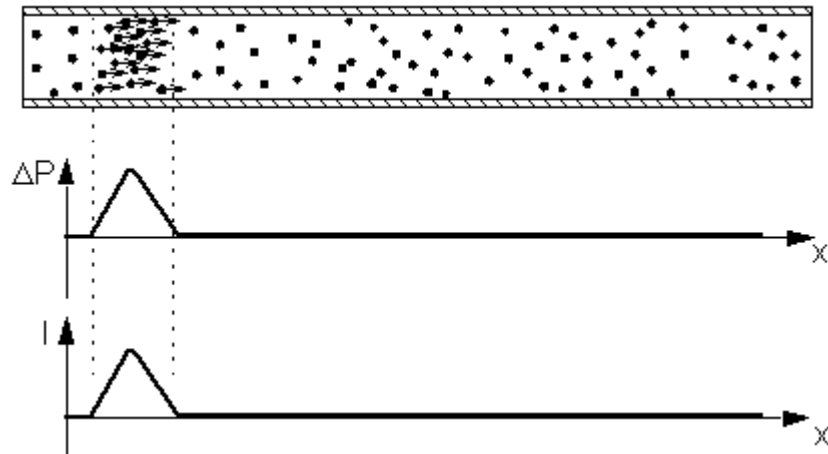

Fig.: 1.2.4. Transition of a pulse along a tube filled with gas or liquid

It seems to be quite natural that such a pulse is transmitted along the tube with constant velocity and without changing its form. When the pulse is hitting the end of the tube, it can either be reflected, partly or completely absorbed.

The simulation displaces such a transmission process and demonstrates these different possibilities. It also presents the superposition of pulses moving with opposite orientation.

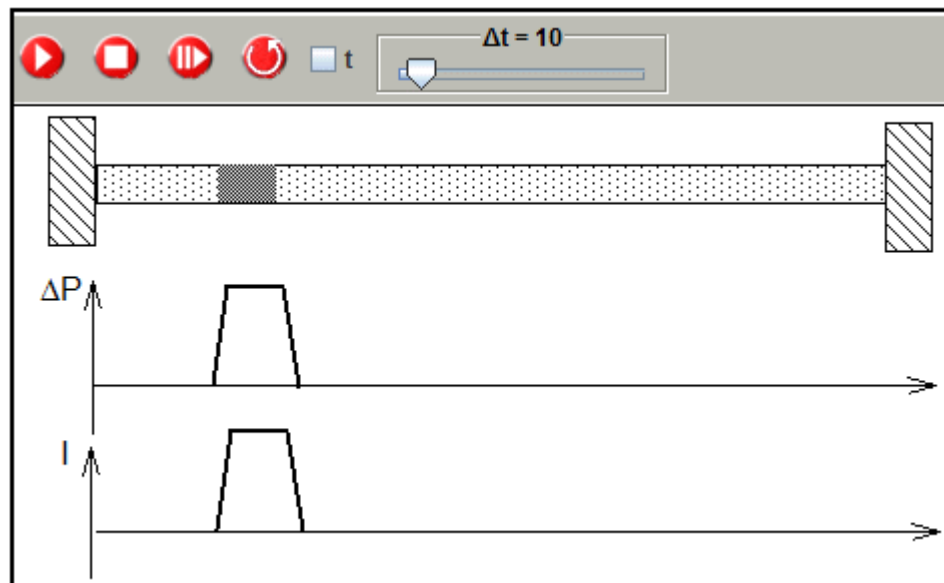

Fig.: 1.2.5. Simulation of the displacement of a small zone with increased pressure

1.2.5. A zone of increased pressure, changing in time

In the following a more complex interpretation of such a transmission process will be presented, which will prove its fruitfulness, when during the following learning process topics like superposition and reflection have to be studied and understood.

The following figure to the left shows one component of a pulse, a zone with higher pressure. To the right is indicated what will happen after a few time steps after the equalization process has been started.

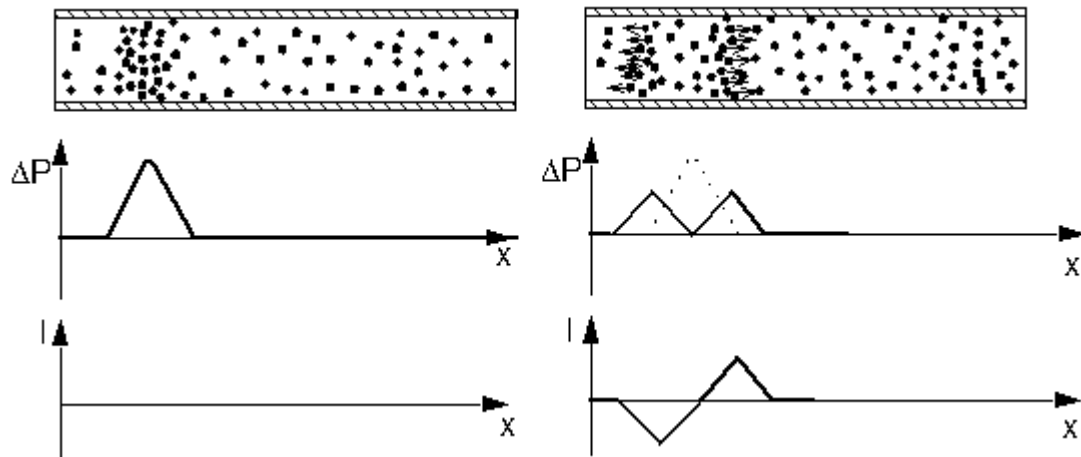



Fig.: 1.2.6. Displacement of a small zone with increased pressure
 left: Starting position
 right: Position after a few time steps

The particles inside of the compressed zone will exert a stronger push on their neighbours on both sides than these can push back. The zone will therefore spread out to both sides, one half starting to move to the right, the other half starting to move to the left.

The diagram indicates this drift velocity by arrows connected to the moving particle. The random velocity, which is usually much larger than the drift velocity, is not shown, although it is of vital importance for the equalization process to occur.

The simulation allows to study this process in detail, by activating the simulation with the step button  not with the run button.

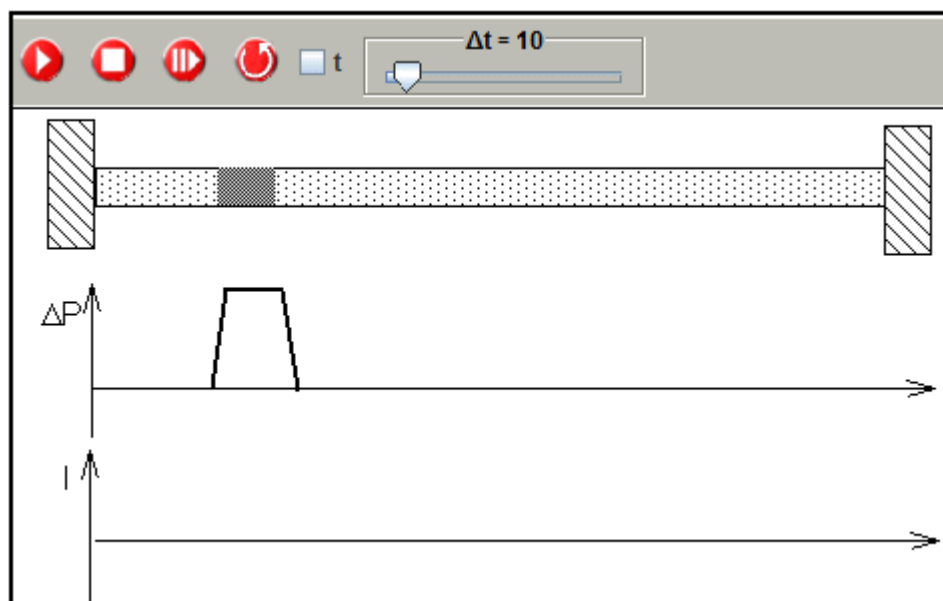

Fig.: 1.2.7. Simulation of the displacement of a small pressure zone

1.2.6. A zone with drifting particles, changing in time

The following figure to the left shows a second component of a pulse, a zone where the particles are drifting in one direction with no increase or decrease of pressure, while the particles outside of this zone are just in thermal motion but not drifting.

It is assumed that this unstable situation has been created in a rather short time. On the right is indicated what will happen a few time steps after the equalization process has been started.

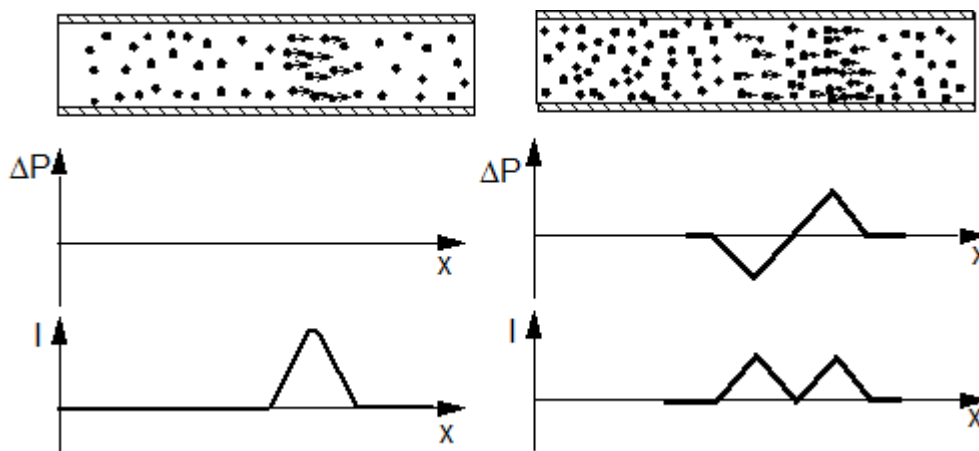

Fig.: 1.2.8. Displacement of a small zone with drifting particles
left: Starting position
right: Situation after a few time steps

In this case there is again a reaction to both sides.

On the right side the drifting particles will cause an increased pressure zone. Because of the unavoidable collision processes they will transmit their drift velocity to the particles in this zone.

On the left side (opposite to the drifting velocity) the drifting particles will leave a depletion zone. The particles within this zone will start drifting to the right, because they experience more collisions from their left neighbours than from the right side, where the particles are drifting away.

This process can be studied in detail with the following simulation.

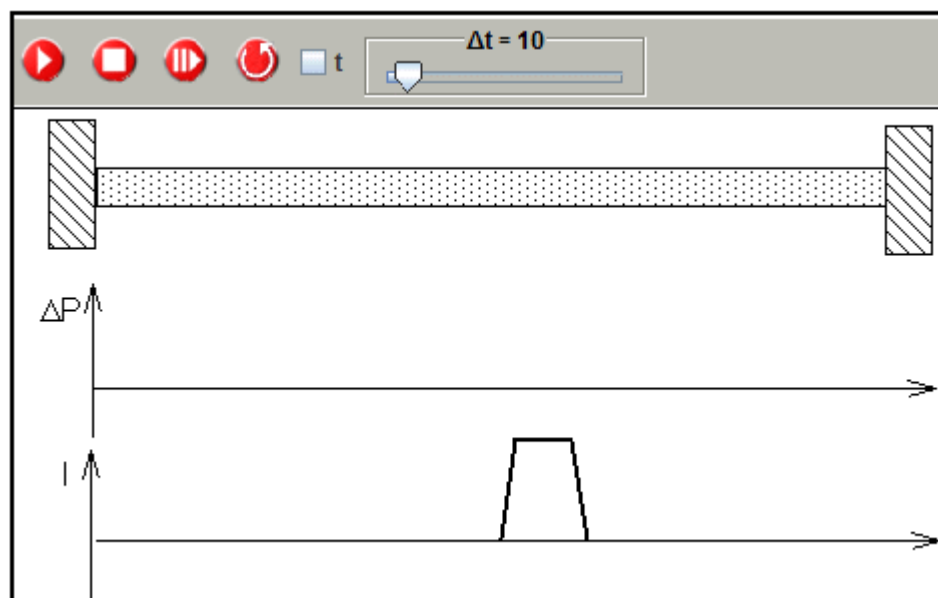



Fig.: 1.2.9. Simulation of the propagation of a zone with drifting particles but no change in pressure

Again it is advised to activate the simulation by using the step button , not the run button.

1.2.7. Transmission of a pulse - a new interpretation

If the two components of a pulse, a zone with increased pressure and a zone with drifting particles are compared and superimposed - see next picture - it becomes obvious, while a pulse is transmitted to one side without changing its form.

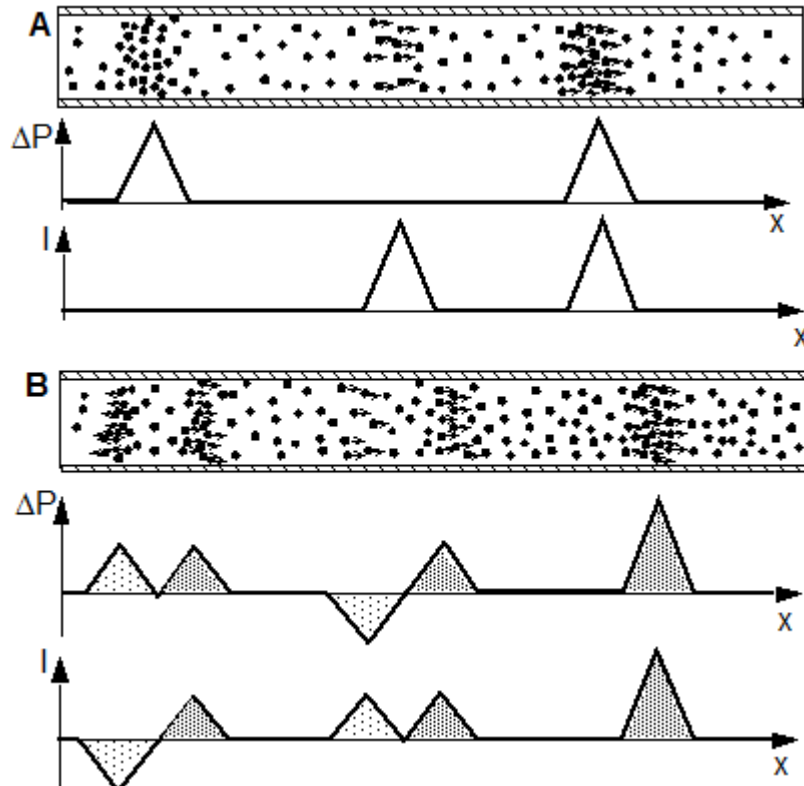

Fig.: 1.2.10. A: Starting situation: A pulse and its components at different locations

B: Situation after a few time steps: Propagation to both sides and pulse transmission

As indicated graphically the propagation of the separated components cancel each other on the left side and add up on the right side. The result is a simple transmission of the original pulse to the right without changing its form.

The simulation allows to study this process in details.

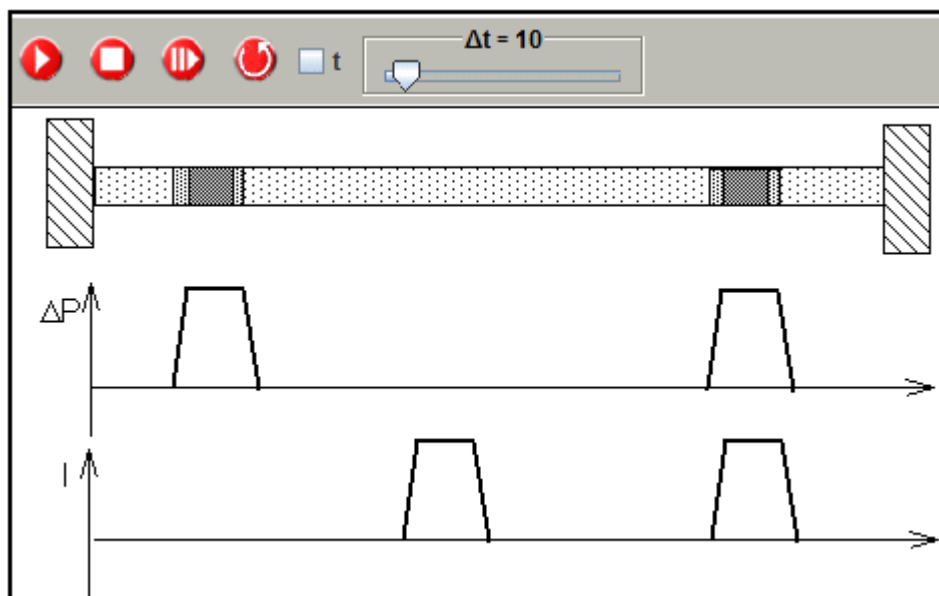



Fig.: 1.2.11. Simulation of the displacement of a pulse and its two components

Again it is strongly advised to activate the simulation by using the step button , not the run button.

1.2.8. Direction of transmission

The previous simulation demonstrated that the movement of a pulse can be explained as the superposition of two effects: one induced by an increased pressure zone (ΔP) and the other induced by a zone with drifting particles (I).

Until now both, ΔP and I were positive, resulting in a pulse or wave front moving in the direction of drifting particles, in our case to the right.

The simulation allows to find out what will happen if ΔP and I have negative or opposite signs.

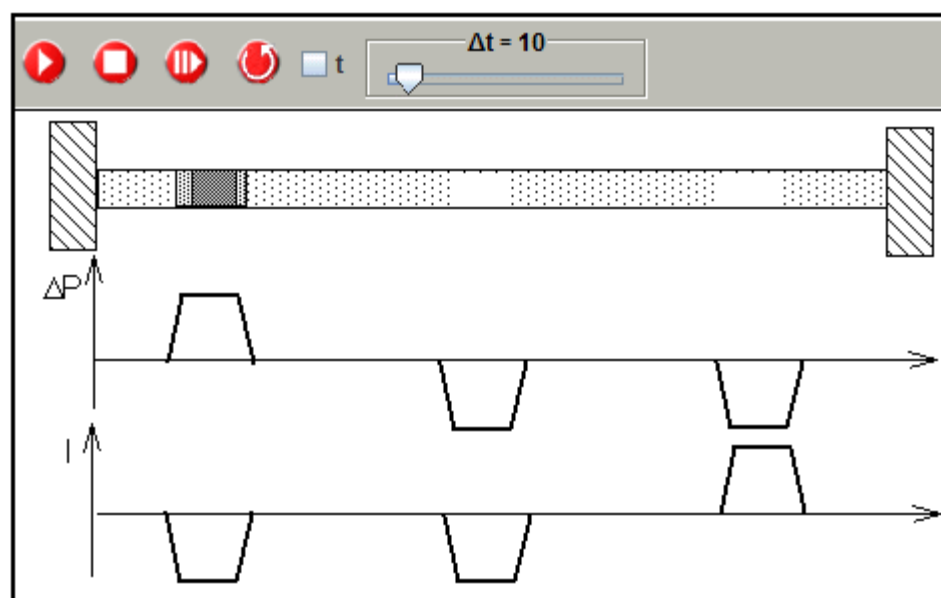

Fig.: 1.2.12. Simulation of pulse transmission in opposite directions

The result showed by the simulation can be expressed in form of a simple rule:

Transmission line

If ΔP and I are both either positive or negative, the pulse is transmitted in the positive direction. If ΔP and I have opposite signs, the pulse is transmitted in the negative direction.

It may be an interesting activity to study the case of a pulse with $-\Delta P$ and $-I$ in detail like in the previous chapter 1.2.7., to understand, why a pulse is transmitted in the positive direction, even so the particles are drifting in the negative direction.

1.2.9. Pulse transmission for an arbitrary ratio of $\Delta P/I$

Based on the previous chapters, two basic results can be formulated.

1. A pulse can be divided into a zone with an increased or decreased pressure (ΔP) and into a zone with drifting particles (I).
2. The transmission of a pulse is a result of the propagation of these two components in both directions.

For the cases discussed in the previous chapters the ratio of $\Delta P/I$ was chosen in such a way that the propagation of ΔP and I canceled in one direction and added up in the opposite direction to produce the original pulse at a displaced position. This, however, is only possible, if the ratio of $\Delta P/\Delta I$ has a specific value.

The following figure shows a situation where the ratio $\Delta P/\Delta I$ has been arbitrarily chosen and where the two components together with the pulse are displaced at separate locations.

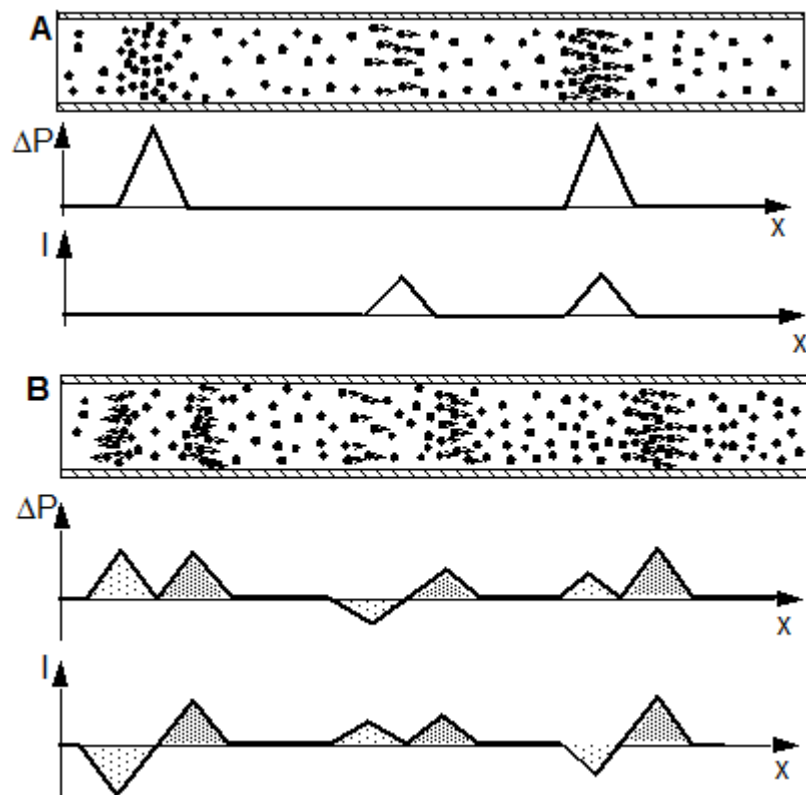

Fig.: 1.2.13. Displacement of a pulse with a changed ratio of $\Delta P/I$

The situation after a few time steps is shown in the lower part (Fig. B). Due to the actual ratio of $\Delta P/I$ the two propagation processes to the left side do not cancel as before. The superposition of these two propagation processes results in a division of the original pulse moving in opposite directions.

The simulation allows to study this process in detail. .

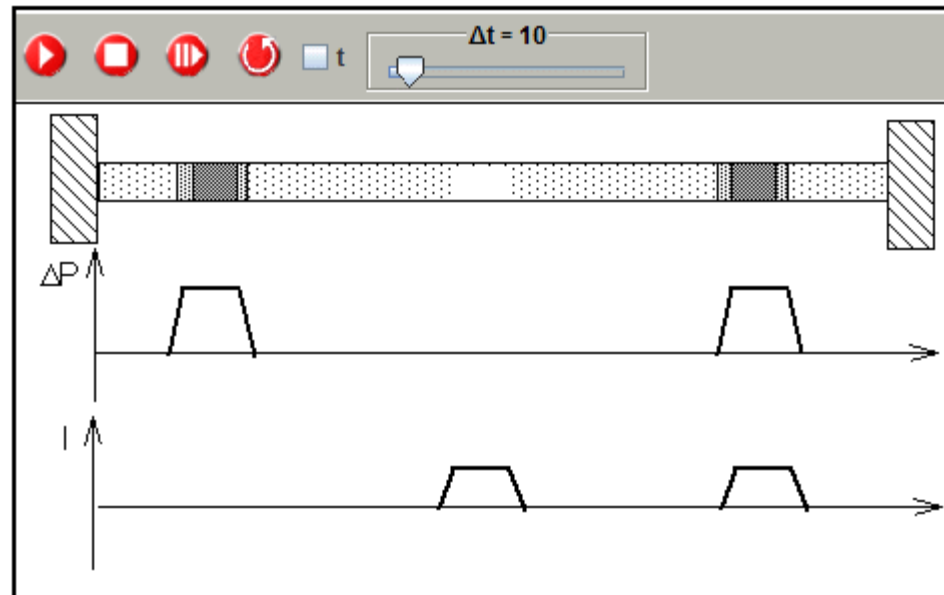

Fig.: 1.2.14. Simulation of the displacement of a pulse with a changed ratio of $\Delta P/I$. By using different starting situation for ΔP and I it can be checked whether the rule, stated above, is generally valid.

1.3. Superposition of pulses in rectilinear tubes

1.3.1. Linear superposition

In the preceding chapter it was explained under what conditions a pulse, formed by a zone of ΔP and ΔI , is transmitted in one direction without changing its form.

In this chapter you will study the result of two wave pulses moving towards and across each other. To do so an important precondition has to be valid. It must be assured that all changes in pressure and current are small in comparison to those changes which are realistically possible in the system under study. If for instance a pipe can hold a pressure of 100 pressure units, we will study only cases with small changes of a few percent of this value. Under those circumstances it can be assumed in a good approximation that two wave pulses together will add up linearly and that no further non-linear effects will occur. The same has to be valid for changes of current. Here too, we will assume only values for I , so that two currents at the same place will add linearly.

1.3.2. Superposition of two pulses of equal seize

The following figure shows two pulses of equal seize which move towards each other. .

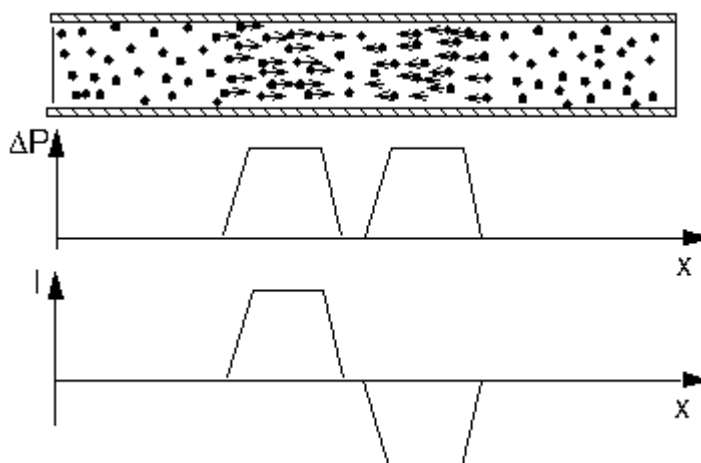

Fig.: 1.3.1. Two pulses moving with opposite orientation

The simulation allows to observe what will be the result when both pulses will have completely overlapped and have separated again.

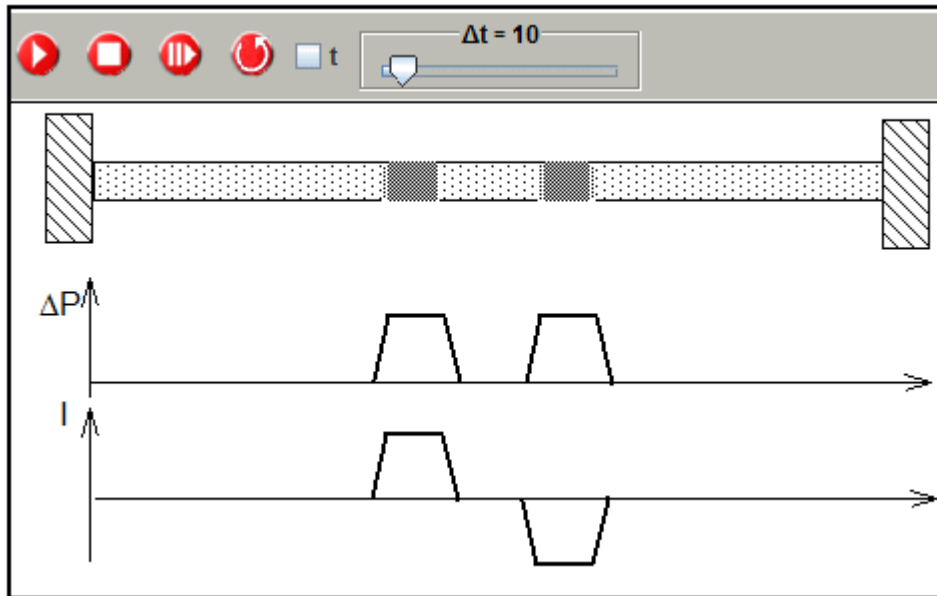

Fig.: 1.3.2. Simulation of 2 pulses moving in opposite direction

It may be helpful to compare these results with what has been discussed in chapter 1.2.5. "A zone of increased pressure"?

1.3.3. Superposition of two pulses of different size

The following simulation allows to observe how two pulses of different size are moving towards each, overlap and separate again.

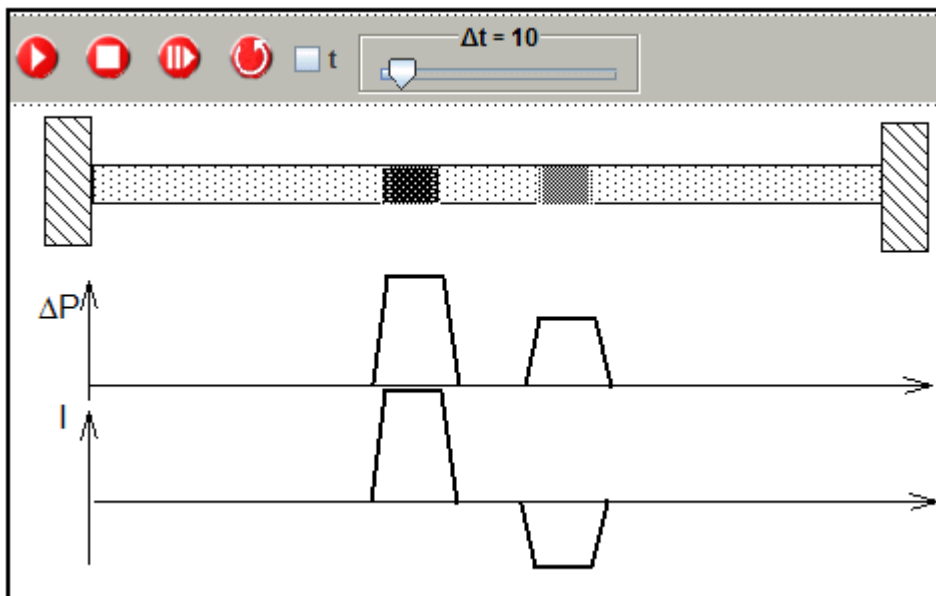

Fig.: 1.3.3. Simulation of the superposition of 2 pulses of different size

What will be the result when both pulses will have completely overlapped? Will this result be different from what has been discussed in chapter "1.2.9. Pulse transmission for an arbitrary ratio of $\Delta P/I$ "

1.4. Transmission in closed circular systems

1.4.1. Introduction

In addition to systems consisting of a single tube with a source and a load at both ends, closed circular systems are found either in nature or in the technical world, where some kind of pump drives a current through a feeding tube, then through some kind of resistor or energy transformer and through a return tube back to the pump.

Such closed circular systems are usually filled with with some kind of liquid. The blood circulating system of mammals is a biological example, the central heat system is a technical one.

Since electrical systems are always based on a circular structure, such circular systems will be studied in detail in the following chapter. It is hoped that the treatment of the more concrete mechanical circular systems will serve as a good and helpful preparation for a study for the more abstract electrical systems, where electric charge carriers are moved around in a closed-loop.

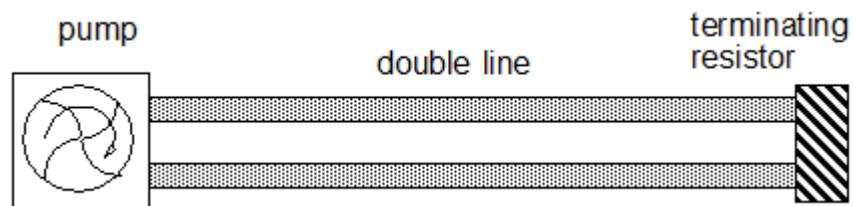

Fig.: 1.4.1. Closed system with feeding line, return line and terminating resistor

In the following a rather simple circular system - a so-called double line - is studied. It is assumed that the tubes, connecting the pump with the resistor are thin, long and straight. Only for these conditions a mathematical theory exists which allows to visualize the corresponding effects, where differences of pressure are shown by colour coding.

1.4.2. Pressure and current on a double line

In a double line a current (left figure) or a pulse (right figure) is caused to flow if a pump is continuously moving material from the returning line to the feeding line. To achieve this effect the pump must keep up a pressure difference between its two outlets. The pressure at the feeding line P_1 must be higher than the pressure P_2 at the returning line.

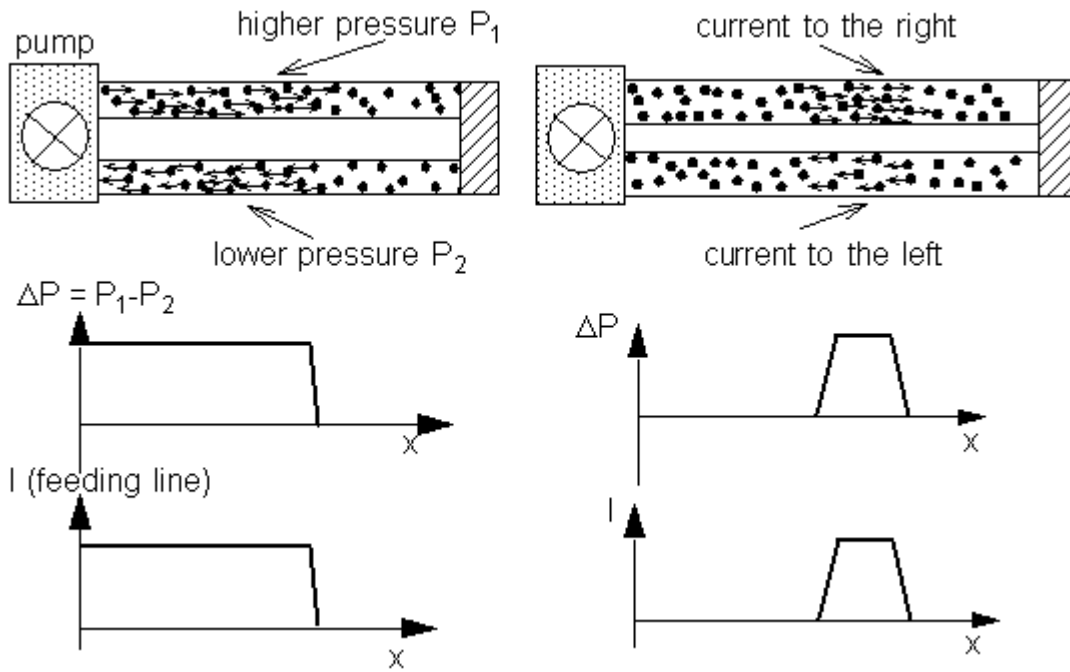

Fig.: 1.4.2. Pressure difference and current for a starting flow (left) and a pulse (right) on a double line

In the returning line a current is produced which is directed towards the pump. In the feeding line the current is directed away from the pump. Based on symmetry arguments it can be concluded that for a given x the absolute values of current and pressure are the same on both lines.

Usually the indication of a current on a double line relates to the feeding line. The value for the returning line is equal but oriented along the opposite direction.

1.4.3. Transmission of a pulse on a double line

If the pump produced a pulse on a double line it will be transmitted to one side. This transmission process can be explained the same way as for a pulse on a single tube.

A single zone with a difference in pressure ΔP between the two line will spread out to both side.

A single zone with drifting particles (in one direction in the feeding line and in opposite direction in the returning line) will spread out to both sides.

The superposition of both zones and processes will cancel on one side and add up on the other, resulting in a transmission of the original pulse without change of form.

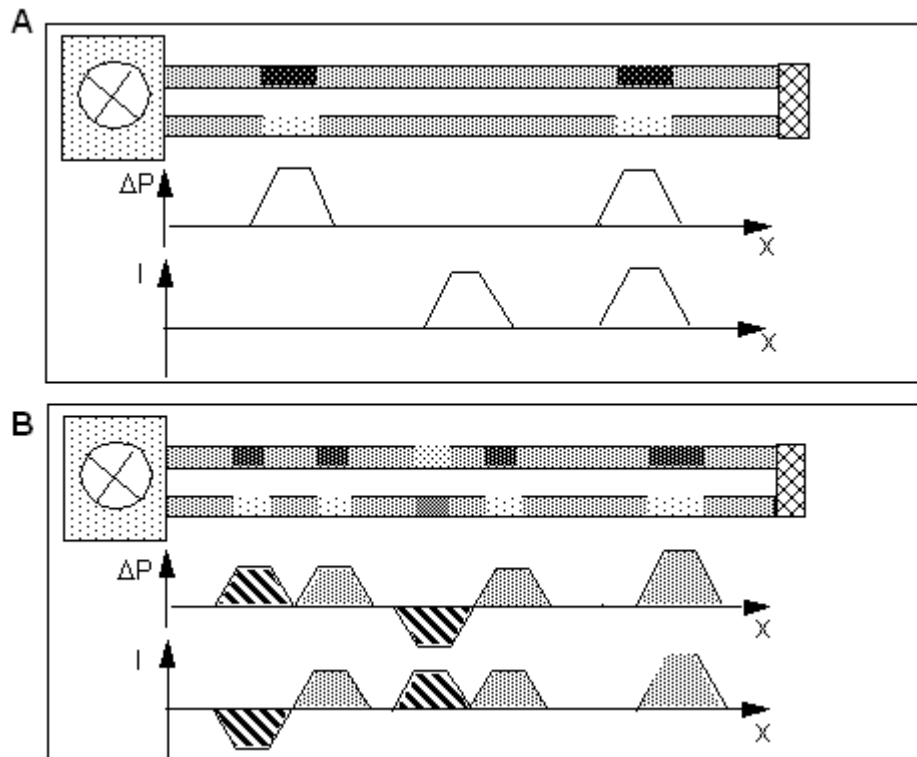



Fig.: 1.4.3. A: Starting situation: 2 separated components and a complete pulse

B: Situation after a few time steps: Propagation to both sides and pulse transmission

The following simulation helps to study this process in detail. To do so it is advised to control the simulation by activating the  button.

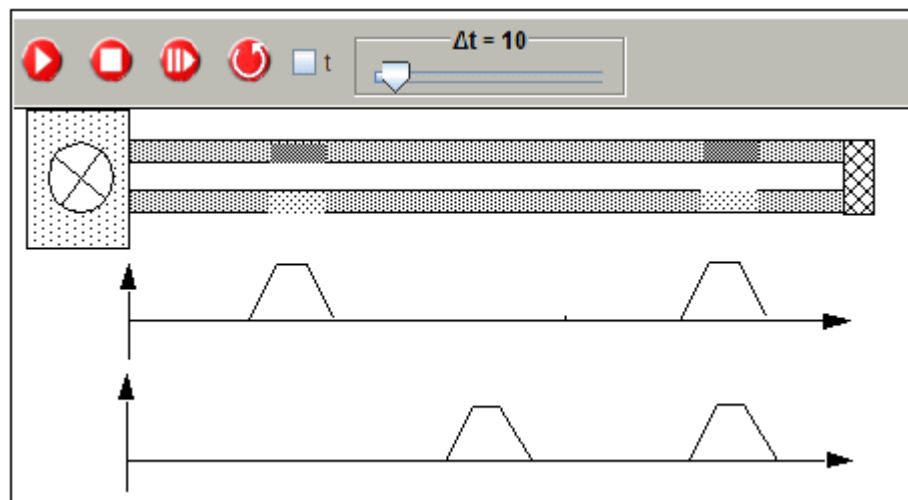

Fig.: 1.4.4. Simulation of the displacement of a pulse and its two components at different locations

1.4.4. Reflection of a pulse at a terminating resistor with $R = \infty$

The following figure shows a pulse on a double line moving towards the closed ending of the tubes.

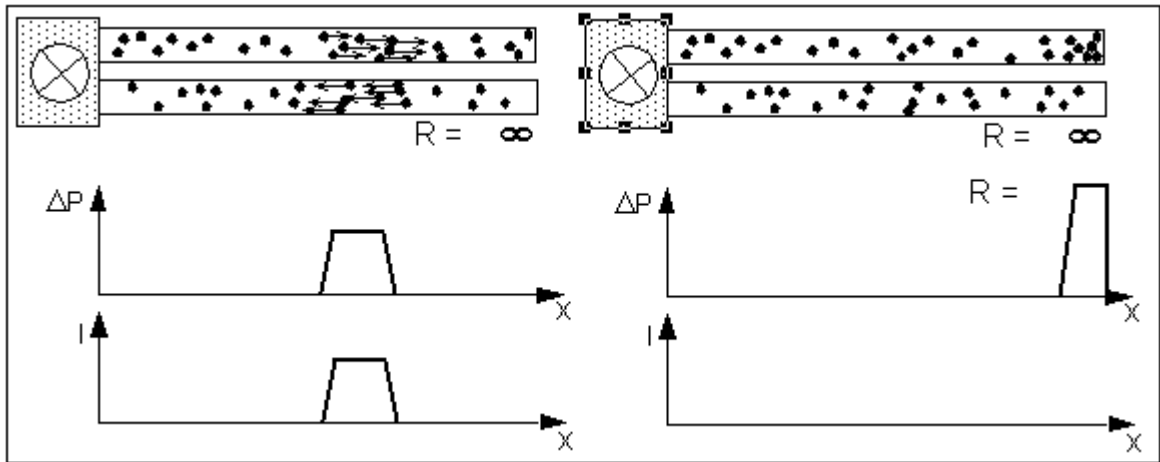

Fig.: 1.4.5. Left: A pulse moving towards a closed end of a double line
 Right: Moment of reflection

By the terminating end of the tube the current is stopped and a zone of increased pressure (on the feeding line but reduced pressure on the return line) is built up in front of it.

After the current has come to a complete stop, a situation is reached which is known from chapter "1.2.5. A zone of increased pressure, changing in time".

We find a single zone with increased pressure which normally should split up in two waves of half size, moving to both sides. The displacement to the right is blocked by the closed end of the pipe and therefore this part is reflected and also displaced to the left. The total result is a reflected pulse of same width and height.

The simulation shows the result of the reflection process.

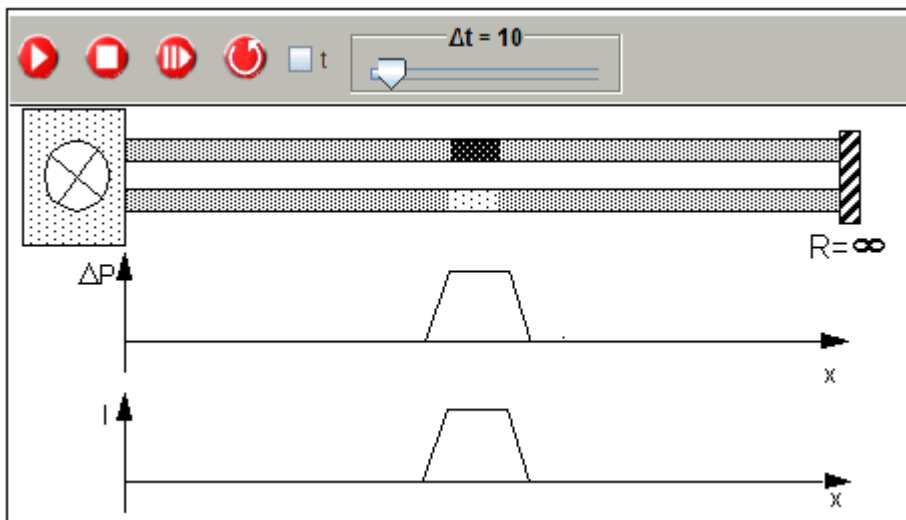

Fig.: 1.4.6. Simulation of a pulse reflection at a closed end of a double line ($R = \infty$)

As result of the reflection process the pulse will be move backwards (change from +I to -I) with no change in ΔP .

1.4.5. Reflection of a current step at a terminating resistor with $R = \infty$

The following figure shows the front of a continuous current moving towards the closed ending of the tubes.

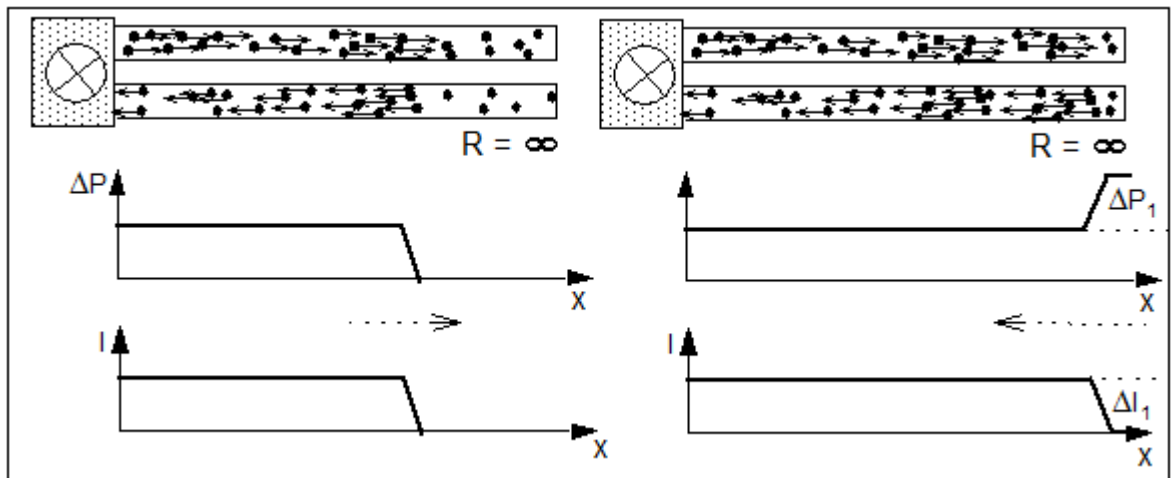

Fig.: 1.4.7. Left: The shoulder of a current moving towards a closed end of a double line
Right: Moment of reflection

The continuous current will come to a halt in front of the resistor by producing an increased pressure. The shoulder formed by ΔP_1 and $-\Delta I_1$ will be transmitted backward to the pump and will bring the complete current to a halt.

The simulation demonstrates this reflection process.

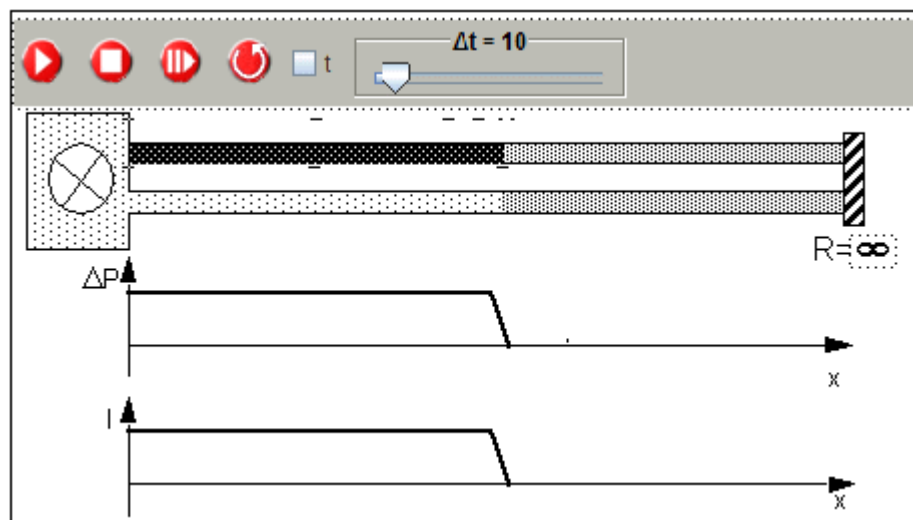

Fig.: 1.4.8. Simulation of a current moving towards the closed end of a double line with $R = \infty$

1.4.6. Reflection of a pulse at a terminating resistor with $R=0$

The following figure shows a pulse on a double line moving towards the ending of the double line where the tubes are connected with practically no resistance.

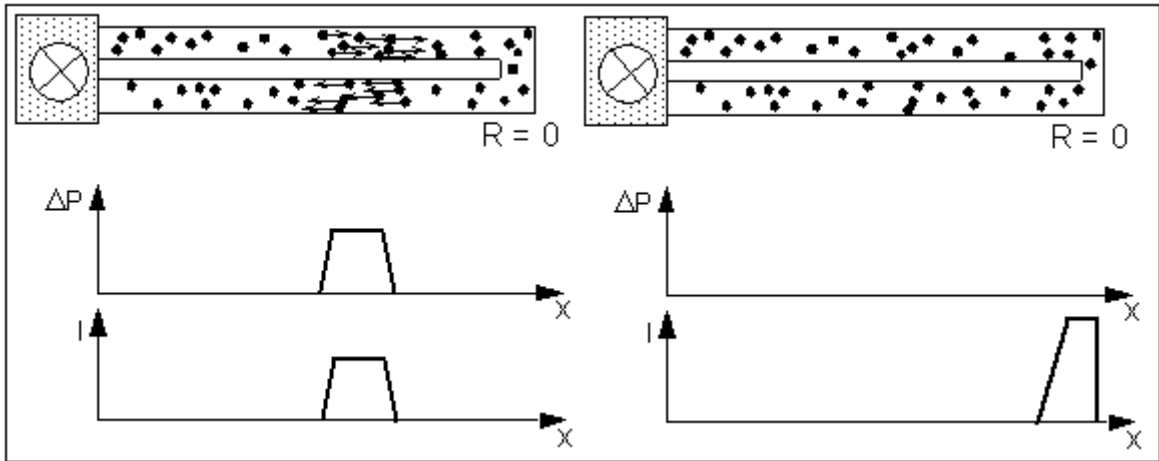

Fig.: 1.4.9. Left: A pulse moving towards the shorted ends of a double line
 Right: Moment of reflection

When a pulse reaches the ending of the double line with $R=0$, the difference in pressure will vanish during the reflection process, but the velocity of the particles will increase.

The situation in the middle of the reflection process is similar to the situation, discussed in chapter "1.2.6. A zone with drifting particles changing in time". The current puls (without any ΔP) at the shorted endings of the double line will spread out to both sides, leading to a puls in backward direction with a change in sign of I and ΔP .

1.4.7. Reflection of a current at a terminating resistor with $R = 0$

The following figure shows the front of a continuous current moving towards the ending of a double line with $R = 0$

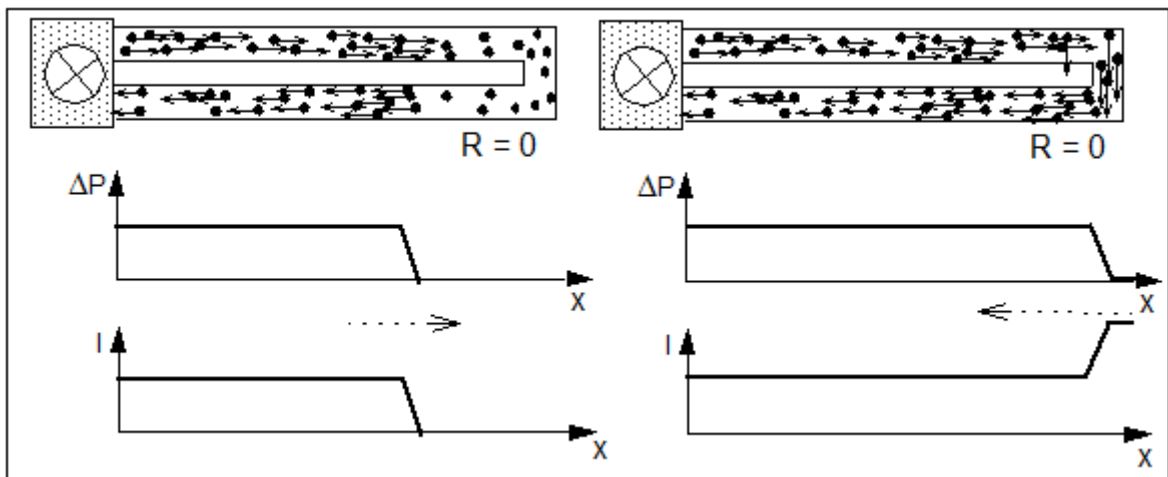

Fig.: 1.4.10. Left: The front of a current moving towards the shorted ends of a double line
 Right: State of pressure and current at the moment of reflection

If a continuous current, produced by a starting pump, is reaching the ending of the double line with $R=0$ the pressure difference will vanish but the drifting velocity of the particle will increase.

The change in the ratio of $\Delta P/I$ will be transmitted backward towards the pump.

The simulation demonstrates this reflection process.

1.4.8. Terminating resistor with no reflection

The resistor at the ending of a double line can have the specific property that the ratio of $\Delta P/I$ of an arriving pulse or wave front does not change during the reflection process. This means that during this process the drifting velocity of the particles in the feeding and returning tube and the pressure difference between these tubes have to be reduced or equalized proportionally. As a result there will be no reflection.

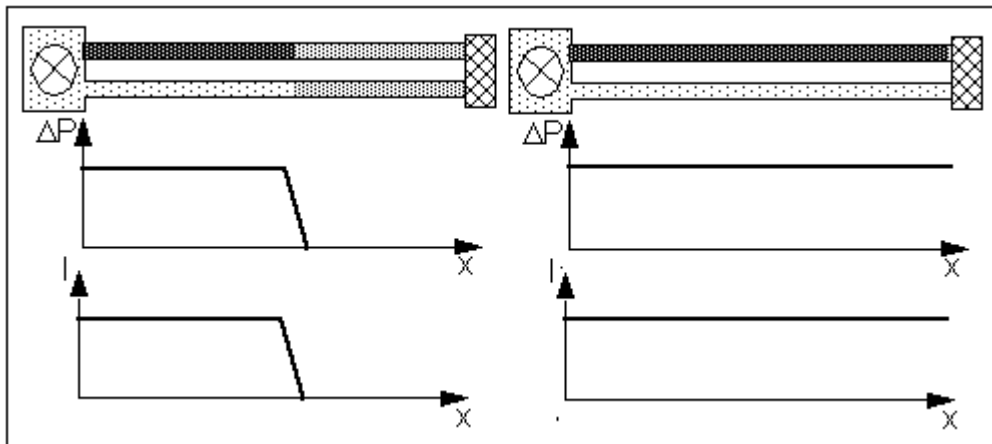

Fig.: 1.4.11. Left: Front of a current moving towards the reflection free ending of a double line
Right: State of pressure and current after "reflection"

The following simulation demonstrates such a case.

It also demonstrates the case of partial reflection, depending on the change of $\Delta P/I$ enforced by the resistance during the reflection process.

Part 2: Transmission in Electrical Systems

2.1. Introduction

A dominant focus of the actual tutorial is set on the continuous use of a simulation program called "TL-Transmission Line - which allows to visualize transmission processes on an electric double line.

The simulation program TL is based on Maxwell's equations in one dimension. The developed algorithm has proved to be stable and correct under all possible conditions.

A documentation of this program can be found under "http://www.astrophysik.uni-kiel.de/~hhaertel/index_e.htm".

Prerequisite for a successful use of this tutorial is basic knowledge about electric circuits as outlined in the tutorial "The so-called simple electric circuit".

A special focus of this tutorial is the treatment of surface charges as a property of current carrying conductors. Knowledge about such surface charges will be helpful if not a prerequisite for a qualitative understanding of the term voltage or potential difference.

A special focus of the actual tutorial are transition processes which always occur when conditions within an electrical system are changed. Here too knowledge about the existence of surface charges is important.

Modern computers offer a new possibility to calculate and visualize such transition processes. This should lead to a deeper and qualitative understanding of electric phenomena. In addition it should induce the learner to careful observation and reflection about the ongoing processes when a system is changing from one steady state to another.

2.2. Transmission processes on a double line

2.2.1. Elements of a double line

In contrary to mechanical systems there are only a few cases where an electric current is not flowing in a closed loop like for instance the de-charging of a capacitor or a lightning, neutralizing separated charges in the atmosphere. In all cases of practical importance only closed electrical circuits exist with two lines, connecting the voltage source with the terminating resistor.

A voltage source is introduced into such a closed circuit at one place to produce an electric current. Such a source will drive electrons from one line to the other. At the other side of the double line we find, as a rule, a resistor, a so-called load, imposing a certain resistance to the drifting flow of electrons.

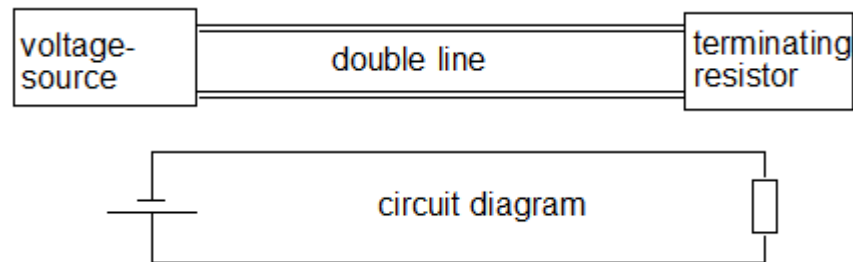

Fig.: 2.2.1 Electric double line and circuit diagram

Similar to a mechanical flow of gas we will make the following assumptions:

- Both parts of an electrical double line are arranged in parallel.
- The distance between them is small compared to their length.

These assumptions lead to following advantages:

- All changes perpendicular to the longitudinal dimension can be neglected.
- Because of symmetry both lines behave identical with the exception of the direction of flow.
- A closed theory, developed by Maxwell in the 19. century, exists for a complete determination of all transmission processes on such double lines.

This theory is the base for all simulations used in this tutorial

2.2.2. Transmission velocity on a double line

In a gas or liquid a non-equilibrium state in respect to density or current is equalized by collisions of thermally activated atoms or molecules. Therefore the transmission velocity of any change in current or pressure could not be faster than the thermal velocity of the colliding microscopic particles. For recall: the thermal velocity of air molecules at room temperature and normal pressure is about 450 m/s.

Within an electric system the transmission velocity does not depend on the velocity of the drifting charge carriers. In contrast to neutral molecules charge carriers are surrounded by an electric field. Changes in the density of charge carriers are leading to changes in the electric field and such changes are spread out with the velocity of light $v = 300.000 \text{ km/s}$.

On an electric double line pulses of voltage and current are therefore transmitted with a velocity comparable with the velocity of light.

In spite of the fact that the transmission velocity is so many orders of magnitude higher than in mechanical systems, the same principles for transmission processes on a double line are valid. These processes will be treated in detail in the following.

2.2.3. Voltage and Current pulses on a double line

Voltage pulse

A double line with a load but without a connected voltage source is in a neutral state and all free electrons are equally distributed. A line with a voltage pulse at a certain place indicates some additional surface electrons at this place on one conductor which are missing on the opposite one.

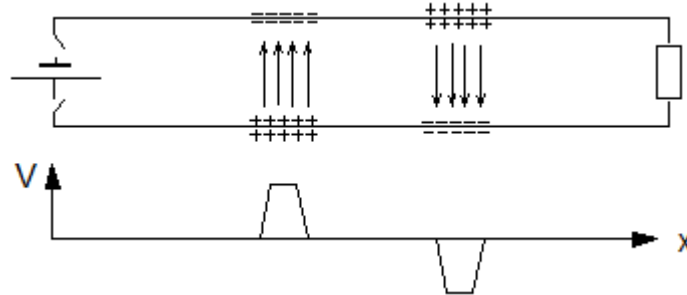

Fig.: 1.2.2. Two voltage pulses of opposite polarity on a double line

Current pulse

The following picture shows a situation which seems difficult to be realized. At a certain moment in time ($t = 0$) all free electrons within a small zone start drifting in one direction (and in the opposite directions on the other line) with no potential difference between the lines.

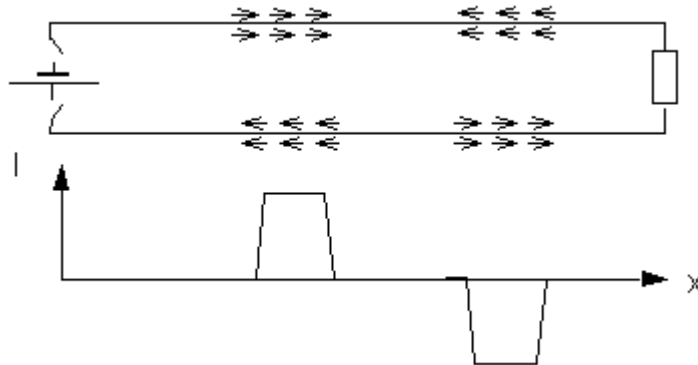

Fig.: 1.2.3. Zones with drifting electrons on a double line

Later it will be seen that such situations can be part of normal processes of reflection and superposition.

2.2.4. Displacement of a voltage pulse on a double line

The following simulation shows a double line with a zone of increased voltage but without any current.

Looking at a microscopic level there are negative charges on the surface of one line, which are missing on the surface of the opposite line. The latter is equivalent with the existence of positive surface charges.

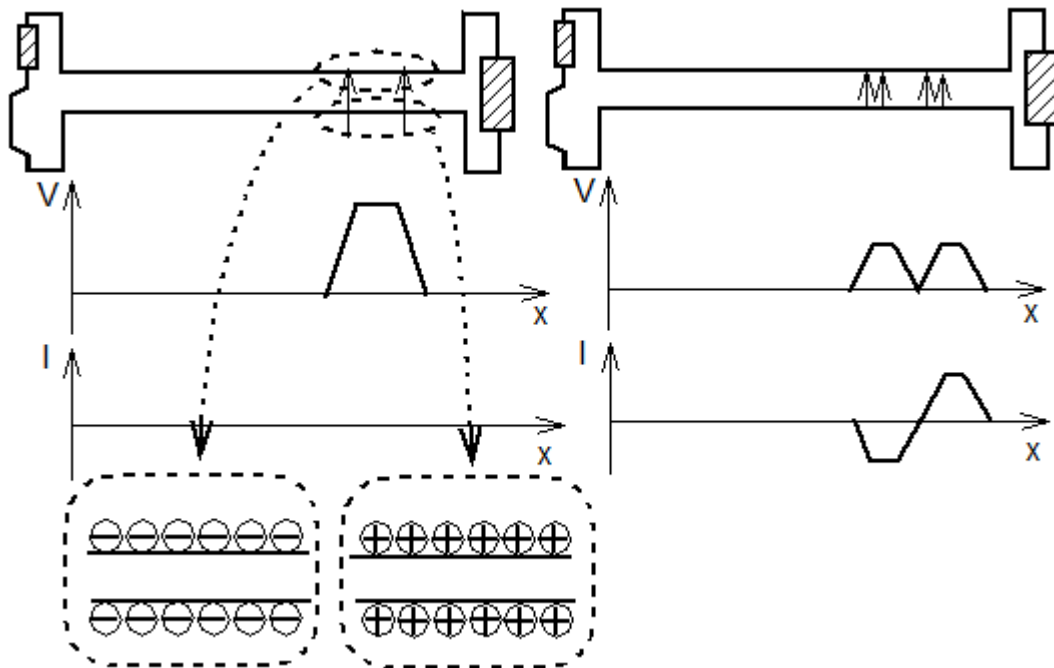

Fig.: 1.2.4. Displacement of a zone with surface charges on a double line
Left: Starting position; Right: Displacement after a few time steps

The negative surface charges repel the other free electrons inside of the wire and each other to both sides, the positive surface charges attract free electrons from both sides. As a result the density of surface charges is reduced in the middle and increased to both sides.

The following simulation demonstrates this effect.

When activating the simulation stepwise it can be seen (like in the mechanical case) that the original voltage zone is split in two wave pulses separating out in both directions.

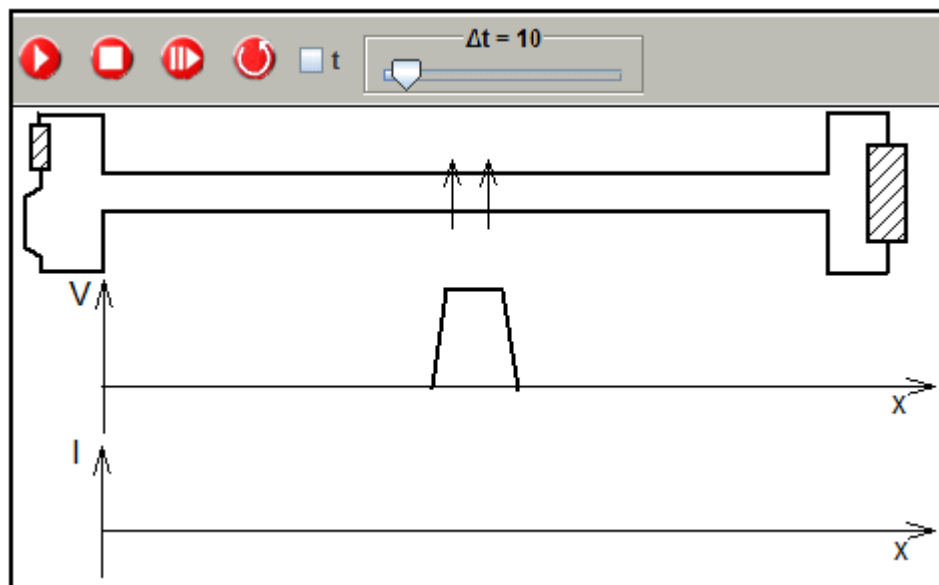

Fig.: 1.2.5. Simulation of voltage zone on a double line

2.2.5. Displacement of a zone with drifting electrons on a double line

The following figure shows a double line with a narrow zone, where the free electrons start to drift at a certain moment in time ($t = t_0$) with no voltage across the line at that time.

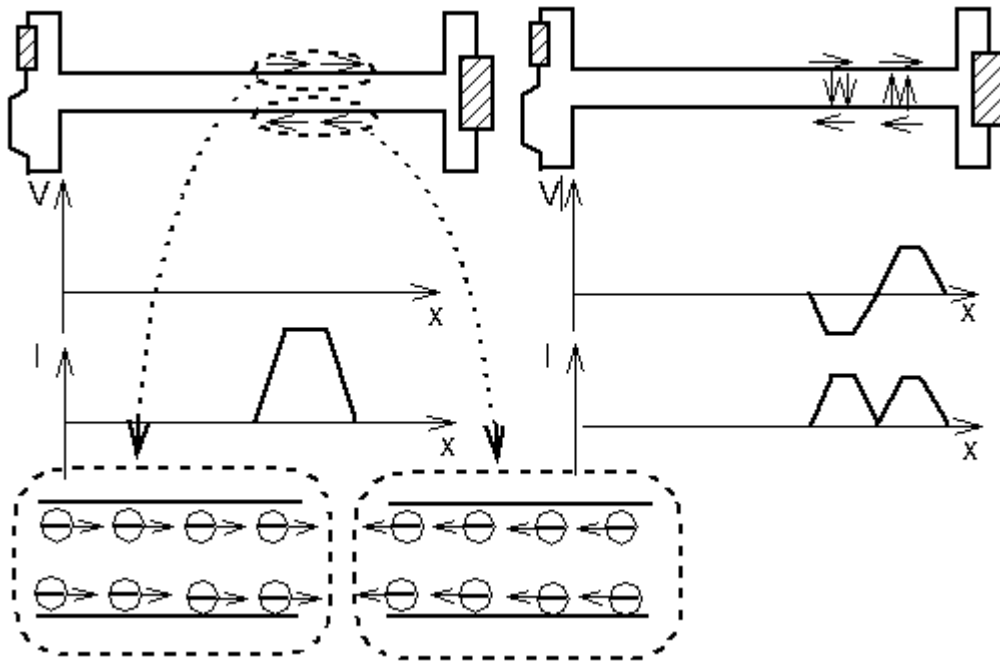

Fig.: 1.2.6. Displacement of a zone with drifting free electrons on a double line
 Left: Starting position; Right: Displacement after a few time steps

Due to interaction with the non-drifting electrons in the direction of flow, the concentration of surface charges will increase. Furthermore a drift velocity will result in the direction of the original flow while the originally drifting electrons will slow down.

In the opposite direction the density of electrons will be reduced, leading to the appearance of positive charges on the surface. The free electrons inside of this zone will experience a reduced interaction with the side where the electrons are drifting away and will start drifting in the same direction.

The simulation allows to study this process in detail...

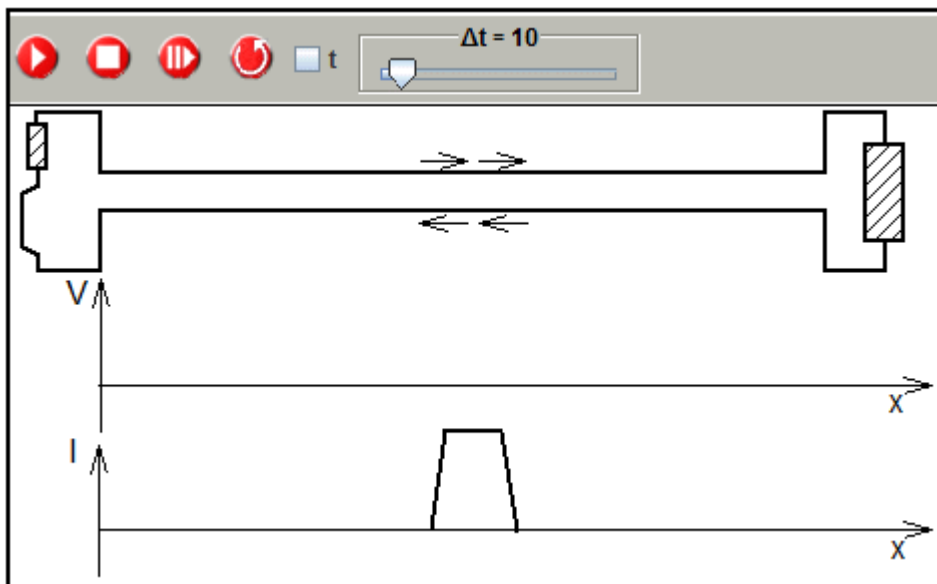

Fig.: 1.2.7. Simulation of a zone with drifting free electrons on a double line
 It is advised to activate the simulation by using the step button.

2.2.6. Transmission of a voltage/current pulse on a double line

A pulse on a double line consist of a zone with surface charges (with opposite polarity on both lines) as well as drifting electrons (in opposite direction in both lines). Such pulses are the basic elements of every digital data transfer.

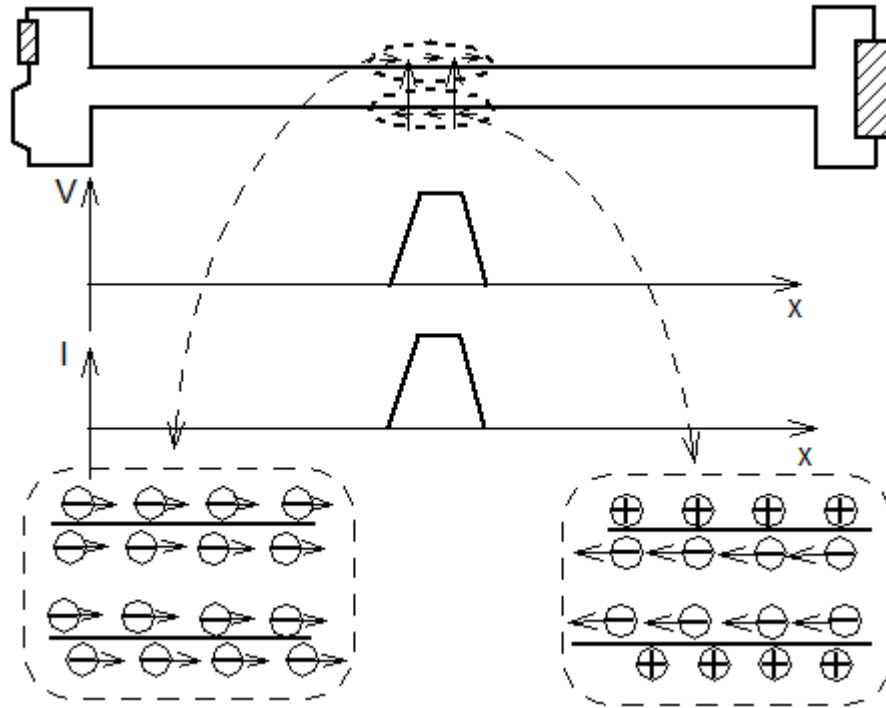

Fig.: 1.2.8. Microscopic view of a pulse on a double line

When studying the mechanical case of a single or double tube it was found that the transition of a pulse can be understood as a superposition of its two components. Both components (ΔP and I) will spread out to both directions. If the ratio $\Delta P/I$ has a specific value, the displacements to one side cancel each other and add up in the opposite direction. The result is a displacement for the original pulse without change of form.

The same interpretation holds of a voltage/current pulse of an electrical double line.

The following figure (A) shows the starting position. If the two components of such a pulse are studied first separately and then superimposed it

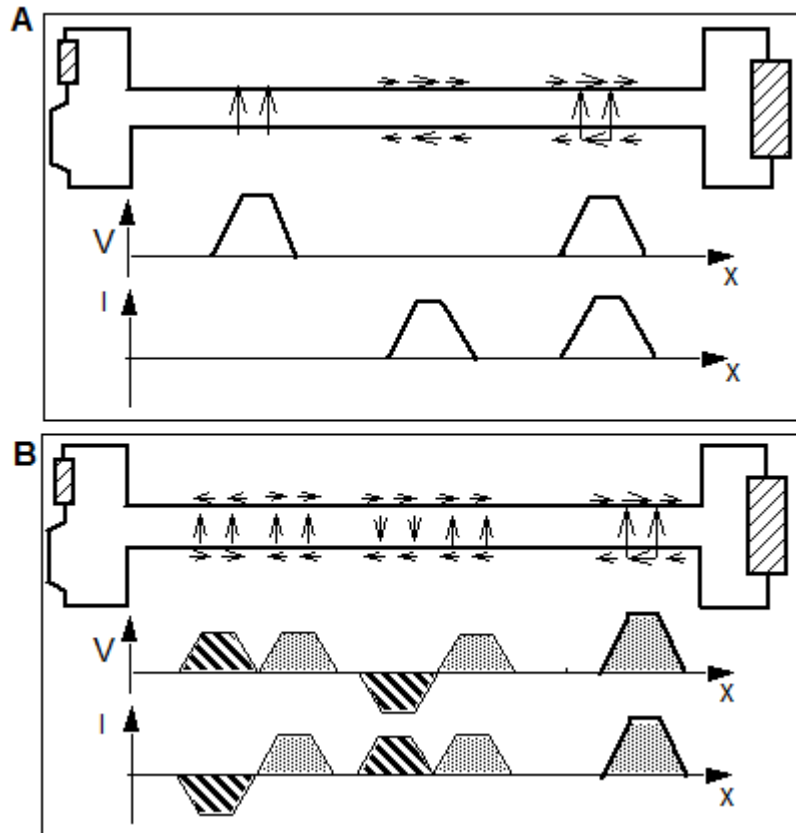

Fig.: 1.2.9. Displacement of a pulse and its components on a double line

A: Starting position; B: Situation after a few time steps

As indicated graphically the displacements of the two components to the left cancel while the displacements to the right add up, resulting in a displacement to the right of the original pulse without change of form.

The simulation allows to study this case in details.

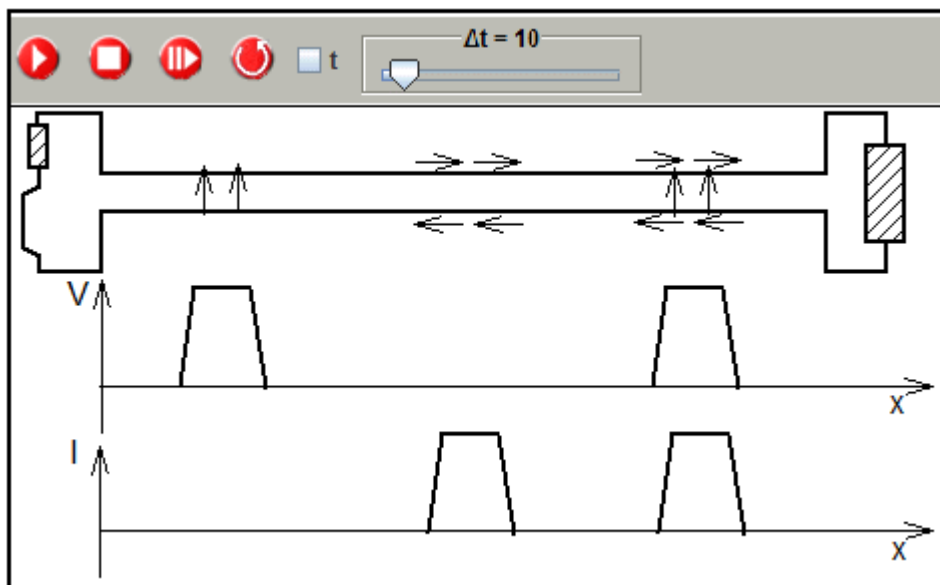

Fig.: 1.2.10. Simulation of the transmission of a pulse and its components on a double line

In the mechanical case a pulse transmission without change of form only occurs for a specific ratio of $\Delta P/I$.

The same holds for the electrical case of a pulse or any kind of wave front on a double line. A transmission without change of form only takes place for a specific ratio of V/I .

2.2.7. Transmission of a pulse with an arbitrary ratio of V/I .

The following figure shows the displacements of a pulse on a double line together with its two components at separate locations. In comparison with the former situations the ratio $\Delta U/I$ has been changed.

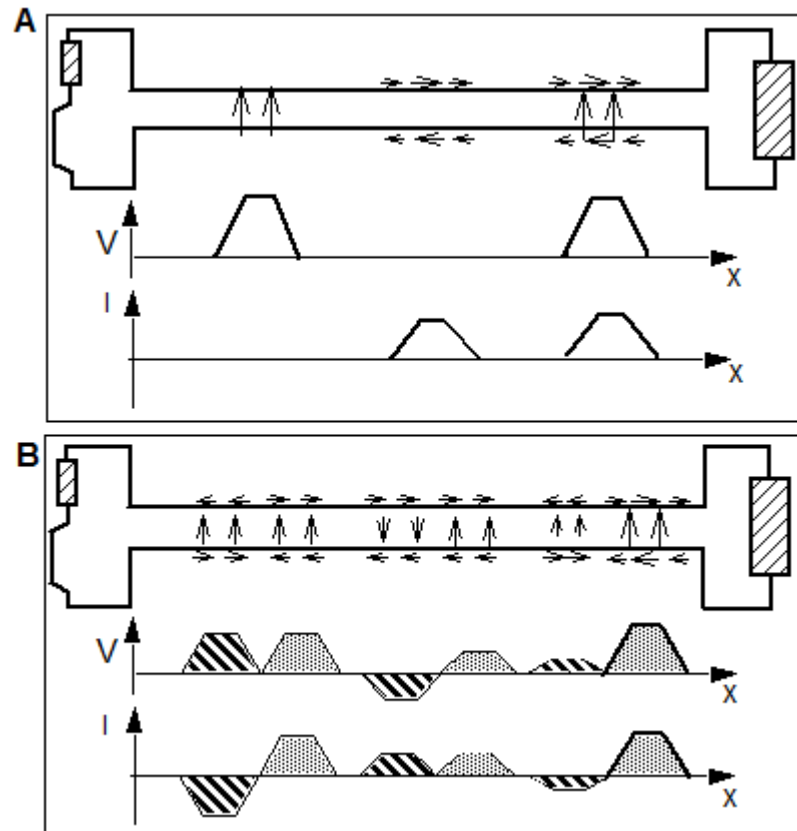

Fig.: 1.2.11. Displacement of a pulse and its components with arbitrary ratio of V/I
 A: Starting position; B: Situation after a few time steps

Due to the arbitrary ratio of V/I the displacement of the two components to the left side do not cancel. As a result the original pulse is not transmitted without change of form but is split into two parts, moving in opposite directions.

The simulation allows to study this process in detail.

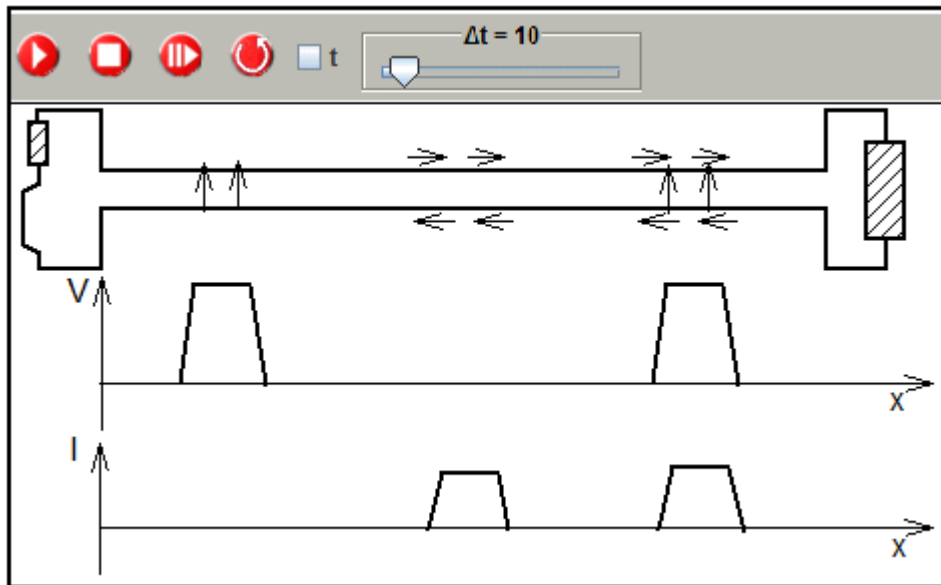

Fig.: 1.2.12. Simulation of a pulse and its components with arbitrary ratio of V/I

2.3. Reflection at a terminating resistor

2.3.1. Reflection at an open end ($R = \infty$)

In analogy to the mechanical case we can expect a reflection, if a voltage/current pulse or a wave front is reaching the terminating resistor, the so-called load, at the end of a double line.

A double line with an open end corresponds to a load with $R = \infty \Omega$

The following figures shows such a case with a pulse just before hitting the open end and at the moment of reflection.

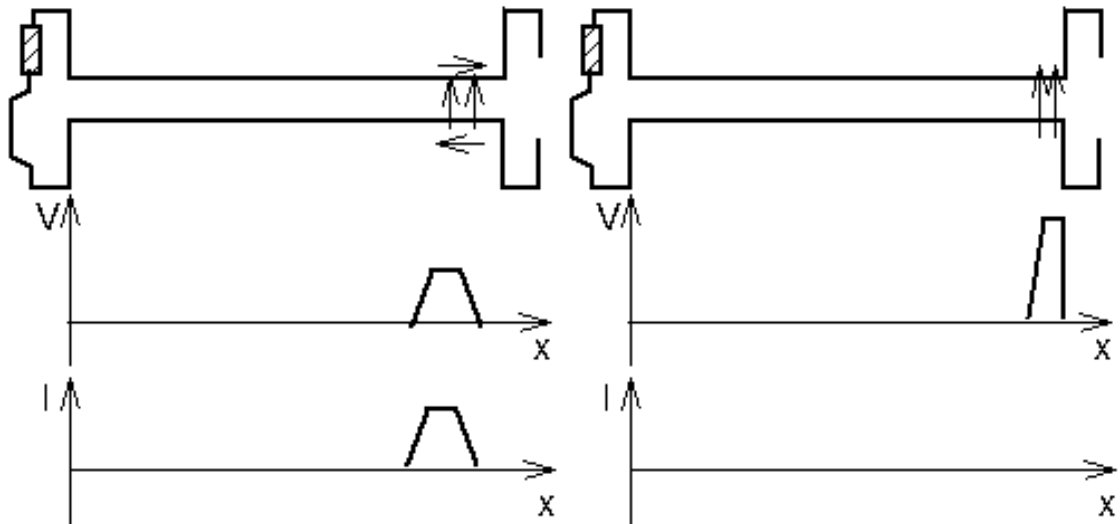

Fig.: 2.3.1. Left: A pulse moving towards the open ends of a double line ($R = \infty \Omega$)
Right: Moment of reflection

When arriving at the interruption the current is stopped while the height of the voltage pulse is increased and its width decreased. When the current has come to a complete stop only a zone with increased voltage on the line remains.

As shown in chapter „2.2.4. Displacement of a voltage pulse on a double line“ such a pulse would split in two parts, spreading out to both sides with equal width and reduced height.

In the actual situation, however, the transmission to the right is not possible because of the infinite resistor, the open endings. Therefore the part originally send to the right will be reflected to the left. As a result we get a reflection of the original pulse with same height and width.

The simulation allows to observe this process in detail.

2.3.2. Reflection at a short circuit as terminating resistor

If the two endings of a double line are directly connected, a so-called short-circuit is formed.

The following figures shows such a case with a pulse just before hitting the open end and at the moment of reflection.

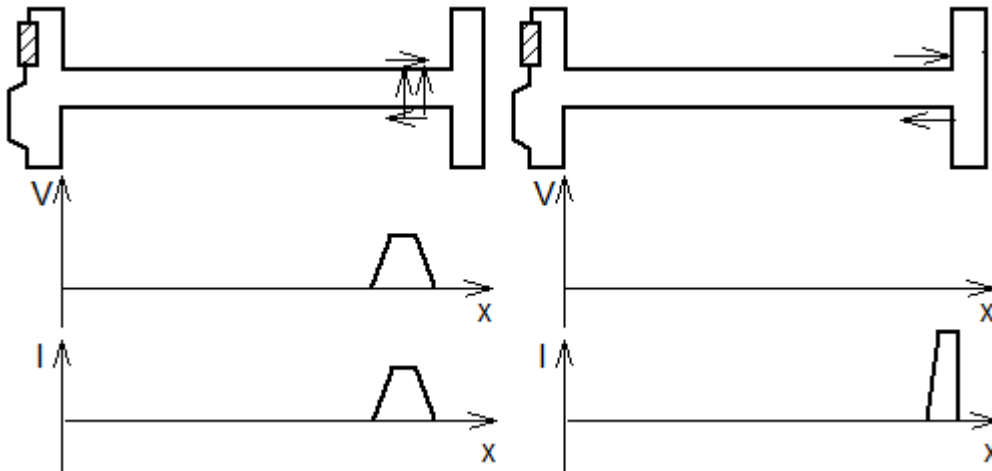

Fig.: 2.3.2. Left: A pulse moving towards the shorted ends of a double line ($R=0 \Omega$)
 Right: Moment of reflection

At the place where both lines are directly connected the surface charges on both lines of different polarity are approaching and neutralizing each other. While approaching the mutual Coulomb interaction is increasing, leading to an increased velocity of the drifting electrons. In the middle of the reflection process no extra charges are left on the surface ($V=0$), however, a zone of drifting electrons exists.

This situation and the following process corresponds to the description given in chapter "2.2.5. Displacement of a zone with drifting electrons on a double line".

Such a zone will normally split in two parts and separate to both sides. At the end of a shorted double line, however, the two parts are moving back towards the source on the two separated lines.

The simulation allows to observe this process in detail.

2.3.3. Terminating resistor for no reflection

In a mechanical closed system a terminating resistor with a specific value could be found which did not cause reflection for any arriving pulse or wave front. The condition was that this resistor should not change the ratio $\Delta P/I$ during the reflection process.

It can be assumed that a similar condition will hold for an electric double line, where the terminating resistor will not change the ratio V/I and will therefore not cause any reflection.

The simulation allows to observe the reflection for various values of R and to determine this so-called matched resistor value for no reflection.

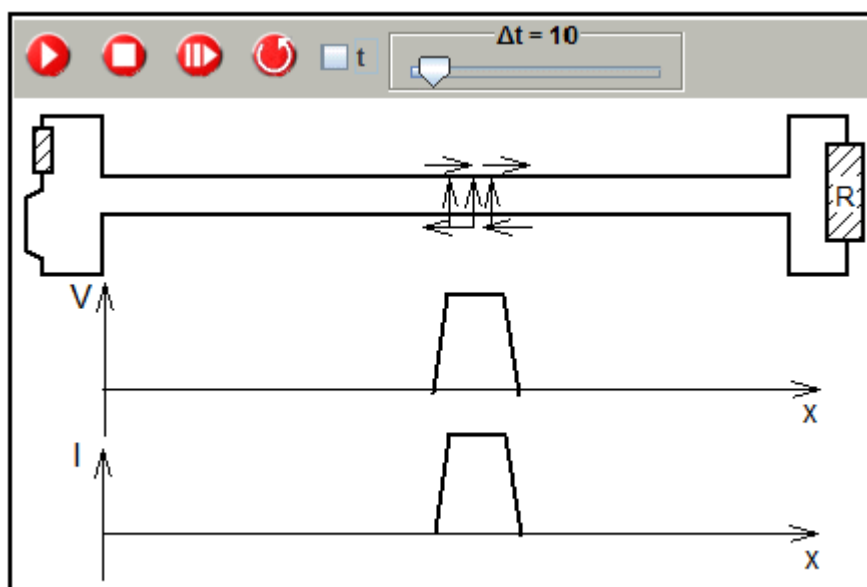

Set $R=20; =30; =40; =50; =60; =70; =80$ units

Fig.: 2.3.3. Simulation of a pulse transmission and reflection on a double line with various terminating resistors

The ratio V/I , which is necessary for the transmission of a pulse or wave front is a property of the related line. It has been given the name impedance, its symbol is Z and it is measure in Ohm.

This ratio is at the same time the condition for a current to flow through a resistor.

Based on these facts it can be assumed that for a double line with impedance Z and a terminating resistor $R = Z$ there will be no reflection. Theory and experiment confirm this supposition.

In all other cases ($R < Z$ or $R > Z$) there will be partial reflection.

It may be a fruitful exercise to analyse the different kinds of reflections for either $R < Z$ and $R > Z$ and to explain the result in a similar way as it was done for $R=0$ and $R=\infty \Omega$.

2.4. Impedance - Wave resistance

2.4.1. Impedance as function of induction and capacitance

A pulse or a wave is transmitted on a double line, if the ratio of V/I has a specific value. This ratio is called impedance or wave resistance and is indicated as Z . It can be interpreted as some kind of resistance and is a specific property of each double line. The larger the amount of Z the more voltage is needed to transmit a pulse with a given current I .

Two characteristics of a double line - the capacity and the inductance - determine the amount of the impedance Z . The meaning of these two terms and their influence on Z will be described in the next sections.

2.4.2. Capacity of a double line

As shown in chapter "2.2. Transmission processes on a double line" a voltage pulse on a double line corresponds to a certain density of additional charges at the surface of opposite line segments.

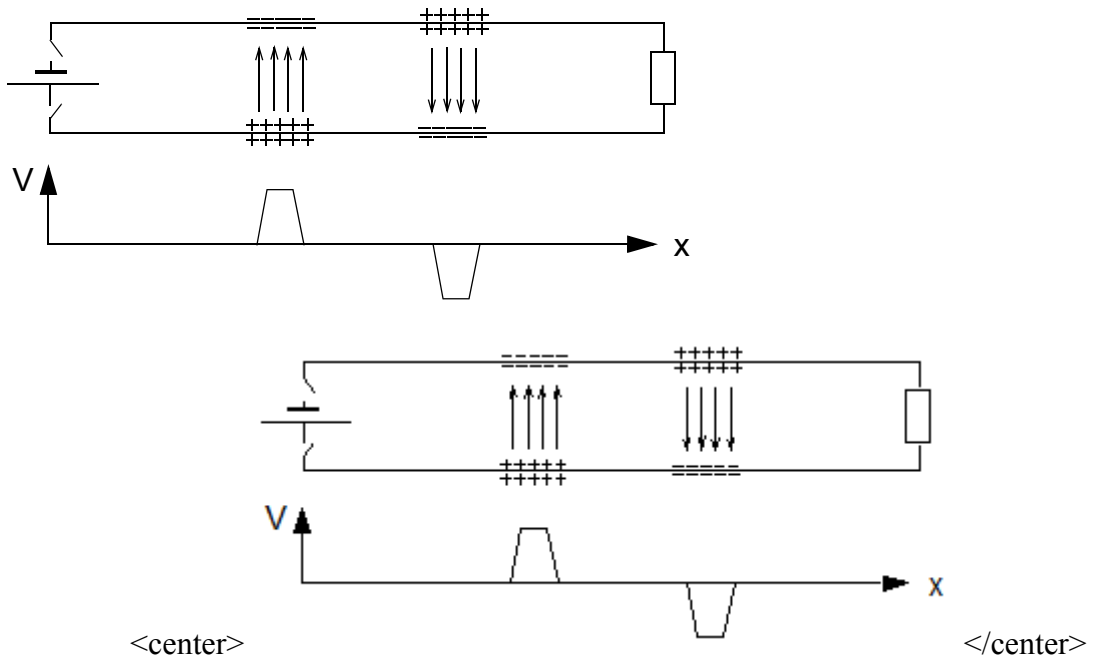

Fig.: 2.4.1. Voltage pulses and surface charges on a double line

Capacity of a line is related to the density of surface charges in relation to the applied voltage. The larger the capacity, the higher the density of surface charges for a given voltage.

There are two possibilities to change the capacity of a line and thus the density of surface charges for a given voltage. One possibility is to change the distance between the two lines, the other is to place some specific dielectric material between the two lines. Both methods have the same effect: the capacity of the line, corresponding to the density of surface charges for a given voltage, is changed.

Further explanations are found under </capacity.htm> Capacitance and Impedance

2.4.3. Inductance of a double line

In case of a flow of gas in a tube it seems plausible that gas with different inertial mass will need a different driving force. A gas like hydrogen with molecules, which have 8 times less mass than Oxygen molecules, will start moving much faster than oxygen gas, and can easily be stopped.

For an electric current an inert behaviour can also be found. However, this effect is not related to the mass of the electrons. The mass is the same for all electrons - there are no "hydrogen" electrons or "oxygen" electrons - and effects due to this mass are so small that they can be neglected.

Electrons are surrounded by an electric field and are impeding each other when ever they are accelerated. The more electrons are starting to move or are changing their drift velocity and the closer they are, the more they are impeding each other. This is a fundamental electric effect, which cannot be explained with mechanical concepts. For a deeper understanding you have to refer to corresponding text books under the headline „Electromagnetic Induction“.

To follow the description below it is sufficient to know that on a double line there exists a kind of inertia for electrons. This inertia will allways show up if the drift velocity of electrons is changed or, more general, if the current is changed.

This inertial like property of a double line is called inductance and is indicated by the letter L. Like with the capacity C the inductance of a double line can be changed by either changing the distance of the conductors or by introducing specific material with magnetic properties between the conductors.

Further explanations are found under [Inductance and Impedance](/inductance.htm)

2.4.4. Relation between Z, L and C

Qualitative description

When increasing the inductance of a double line, a given voltage V will produce a smaller current I because the impeding interaction between the electrons is increased. Therefore the ratio $Z = V/I$ is increased.

When increasing the capacitance of a double line, some additional electrons are necessary to keep up a given voltage. Therefore the current I is increased in relation to V, corresponding to a decrease of $Z = V/I$.

Quantitative description

Derived by theory and proven by experiment the relation between L, C and Z is:

$$Z = \sqrt{L/C} \quad Z = \sqrt{L/C}$$

If L is measured in Henry and C in Farad the unit for Z is Ohm.

For the impedance Z of a double line it is therefore of no importance if for instance the capacity is reduced by a factor of 2 or the impedance is doubled. Another example: If the capacitance and the inductance are both changed by the same factor, the impedance remains unchanged.

After starting the simulation a wave front is moving along the line where the ratio $Z=V/I$ varies with C .

The numerical value for Z can be found by determining the resistance of the load which gives no reflection. The numerical value for the resistance of the load can be entered in the corresponding dialog window.

2.4.6. Double line with variable inductivity

The simulations program TeEl offers the possibility to vary the value for L for the complete line without changing C .

This is realized in an experimental setup by placing magnetic material between the lines.

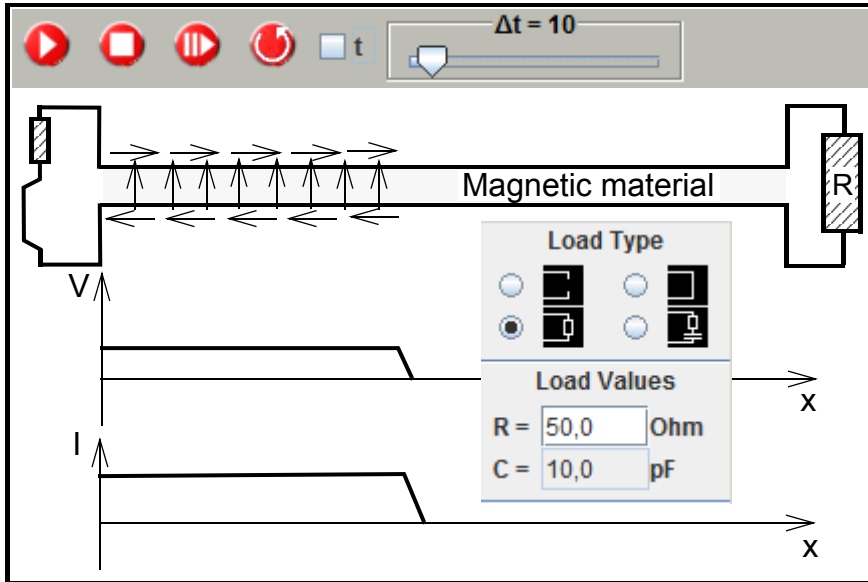

Set $L=L_1; =L_2; =L_3$

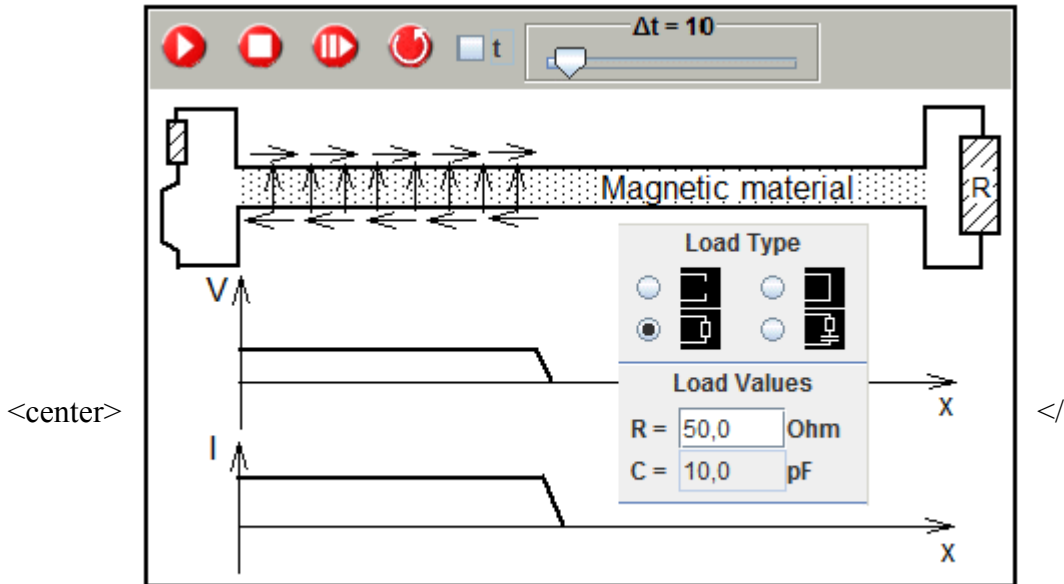

Set $L=L_1; =L_2; =L_3$

center>

Fig.: 2.4.3. Wave front on a double line with variable inductivity

 Set $L=L_1$ (Starting

2.5. Series and parallel circuits

2.5.1. Voltage source with internal resistor

Each source producing a voltage has an internal resistance.

The general circuit diagram for such a voltage source is represented as a voltage source and a resistor in series.

Internal resistor R_i
of the voltage source

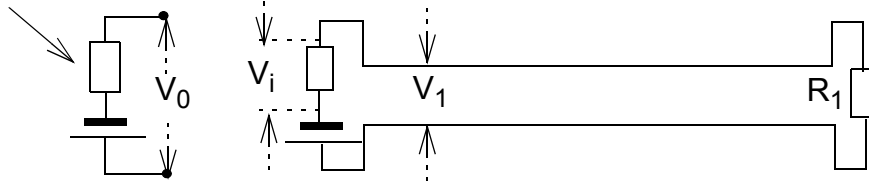

Internal resistor R_i
of the voltage source

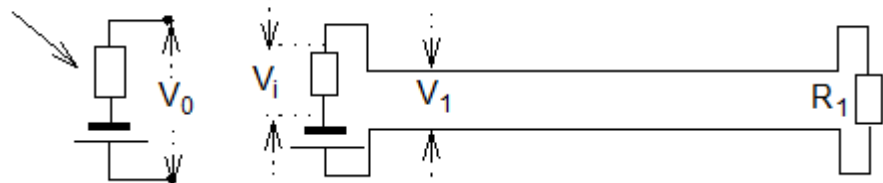

<center>

center>

</

Fig.: 2.5.1. Double line with voltage source and internal resistor

If no current is flowing, the so-called off-load voltage V_0 is measured between the outlets of the source.

If a current is flowing a voltage drop is found across this resistor R_i and only a reduced voltage is available at the external side.

The simulation allows to change the internal resistor R_i in order to study its influence on voltage and current on the double line.

```
<p>Set      R<sup>I</sup>=<a      href="javascript:parent.frames['simulator'].docu-
ment.Teel._readState('./10_E_rup/r_source_30.xml'); document.Teel._simulation.update();">
30      </a>      &nbsp;&nbsp;&nbsp;<a      href="javascript:parent.frames['simulator'].docu-
ment.Teel._readState('./10_E_rup/r_source_50.xml'); document.Teel._simulation.update();">
50      </a>      &nbsp;&nbsp;&nbsp;<a      href="javascript:parent.frames['simulator'].docu-
ment.Teel._readState('./10_E_rup/r_source_70.xml'); document.Teel._simulation.update();">
70 </a> units
```

Result:

The larger the resistance R_i the smaller the voltage applied to the double line and the smaller the current and vice versa.

2.5.2. Double line with constant resistance on the lines

With all simulations used so far it was supposed that no losses are found on the lines. This is an idealisation which, for short lines, comes very close to reality. However, for longer lines losses are always present and can have a strong influence on the transmission of pulses.

The behaviour of such so-called lossy lines will be studied in the following. To do so it is assumed that both conductors of a double line provide a uniform resistance R_L for electric cur-

rents. This implies that per unit length a certain voltage is needed to drive a certain current through these conductors.

The simulation offers the possibility to study the influence of the line resistance on voltage and current along the line.

```
<p>Set      R<sup>line</sup>=<a      href="javascript:parent.frames['simulator'].document.Teel._readState('./10_E_rup/r_loss_30.xml'); document.Teel._simulation.update();"> 10
</a>      &nbsp;&nbsp;&nbsp;&nbsp;<a      href="javascript:parent.frames['simulator'].document.Teel._readState('./10_E_rup/r_loss_50.xml'); document.Teel._simulation.update();"> 50
</a>      &nbsp;&nbsp;&nbsp;&nbsp;<a      href="javascript:parent.frames['simulator'].document.Teel._readState('./10_E_rup/r_loss_100.xml'); document.Teel._simulation.update();">
100 </a> units</p>
```

Question:

Please observe voltage and current at the left entrance of the double line.

Why is the voltage at the entrance of the double line increased, when the loss-less lines are replaced by lines with resistance?

[Answer](/ass2.htm)

2.5.3. Double line with uniform conductivity between the lines (leakage)

The simulation program TL offers the possibility to simulate the influence of conductive material placed between the lines. As a result the two lines are electrically connected along their total length. The resistance of such so-called leakage resistor can be changed.

In practical cases such leakage between conductors of a line is rather small and can often be neglected. In principle, however, it always exists.

The simulation allows to study its influence on the transmission of voltage and current.

```
<p>Set      R<sup>leakage</sup>=<a      href="javascript:parent.frames['simulator'].document.Teel._readState('./10_E_rup/r_leakage_100.xml'); document.Teel._simulation.update();"> 400 </a> &nbsp;&nbsp;&nbsp;&nbsp;<a      href="javascript:parent.frames['simulator'].document.Teel._readState('./10_E_rup/r_leakage_200.xml'); document.Teel._simulation.update();">
200 </a> &nbsp;&nbsp;&nbsp;&nbsp;<a      href="javascript:parent.frames['simulator'].document.Teel._readState('./10_E_rup/r_leakage_100.xml'); document.Teel._simulation.update();"> 100 </a> <a      href="javas-
cript:parent.frames['simulator'].document.Teel._readState('./10_E_rup/r_leakage_50.xml');
document.Teel._simulation.update();"> 50 </a>units</p>
```

Question:

Please observe voltage and current at the left entrance of the double line. Why is this current increased, when the leakage resistor $R(p)$ is applied in parallel to the load?

[Answer](/ass3.htm)

2.5.4. Single resistors on a double line

The simulation program TL offers the possibility to place on each line in the middle between load and source a resistor R_m of variable resistance. The result is a circuit with 3 resistors in series.

These additional resistors in the middle of the lines will cause a change in the ratio of $\Delta U/I$. A transmitted wave front or pulse will therefore be partly reflected.

Only after these reflections have faded away a dynamic equilibrium will be established, for which Ohm's law is valid.

The simulation allows to study these reflection processes for various resistors.

2.5.5. Single resistor in parallel on a double line

As a rule the two conductors of a double line are isolated from each other and the resistance between them is practically infinite.

To study the behaviour of parallel circuits, however, the simulation program TL offers the possibility to simulate the influence of conductive material of a certain width and with variable resistance, placed between the two lines in the middle between source and load. Together with the load such a resistor forms a parallel circuit.

The parallel resistance causes a change of the ratio of U/I and therefore a wave front or pulse will be partly reflected.

Only after these reflections have faded away a dynamic equilibrium will be established, for which Ohm's law is valid.

The simulation allows to study these reflection processes for various resistors.

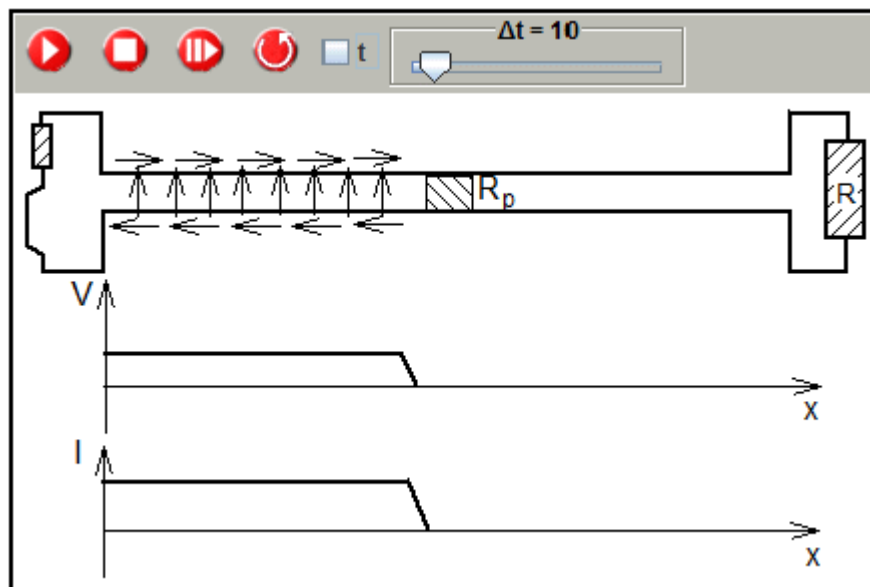
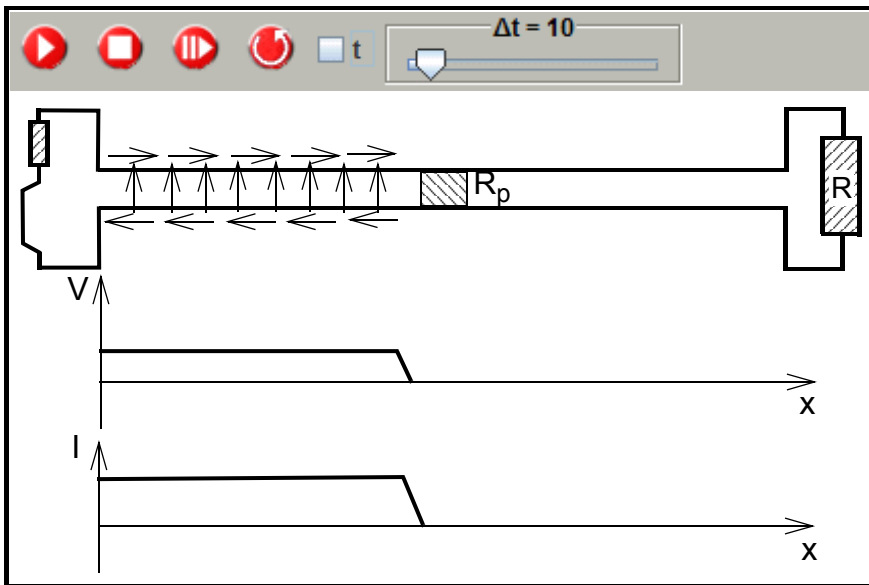

<center>

</center>

Fig.: 2.5.3. Double line with an additional resistor in parallel with the terminating resistor

```
<p>Set R<sub>p</sub>= <a href="javascript:parent.frames['simulator'].document.Teel._readState('./10_E_rup/r_p_10.xml'); document.Teel._simulation.update();"> 10</
```